



THE PREVENTIVE MAINTENANCE MONTHLY

TB 43-PS-697, The Preventive Maintenance Monthly, is an official publication of the Department of the Army, providing information for all soldiers assigned to combat and combat support units and all soldiers with unit maintenance and supply duties. All information published has been reviewed and approved by the agency responsible for the equipment, publication or policy discussed. Application of the information is optional with the user. Masculine pronouns may refer to both genders. The use of product or company names does not constitute endorsement of those products, services or companies by the U.S. Army.

ISSUE 697 DECEMBER 2010



COMBAT VEHICLES

Stryker Winch Pulley Lubing
M1A1 Tank GPS Desiccant Assembly Cover
M1-Series Tanks, Wolverine Road Arm Cracks
DSESTS Turn-in
Bradley AAL Addition
AVLB Launcher Hydraulic Level Check
M109A6 Engine Coolant Hose NSN
M113A2-Series FOV Hydraulic Line Nut



WHEELED VEHICLES

Stryker RWS, CROWS II Cover Differences
Wheel Assembly NSNs
Engine Cooling Systems PM
Trailer Landing Leg AAL
M809-Series Tachograph Kit
M939/A1/A2-Series Wheel Stud Nut



MISSILES

MLRS Wash Rack Cautions



SMALL ARMS

M9 Bayonet Sharpening Stone
Ammo Handling
M249 Machine Gun Gaging
Mortar Tube Danger
M2 Machine Gun SRTA Requirement
M16 Rifle, M4/M4A1 Carbine Bolt Differences
LAR Assistance

The Nightmare Before PMCS

2



AVIATION

35

2 UH-60, AH-64 Stabilator Covers 35-37
3 Aircraft Winter Maintenance Tips 38-40
4-5 Fuel Handler Coverall NSNs 40

6-7

7

8-9

9

9



COMMUNICATIONS

41

SINGGARS MT-6352/VRC Grounding Caution 41
SINGGARS Antenna Offset Kit 42-43
Commo/Info System Cold Weather Reminder 43
Generator Fuel Tanks 44-45
SINGGARS External Antenna Connector 46
Battery Calculator Website 46

10-11

10-13

14-16

17-18

18

18



COMBAT ENGINEERING

46

M929, M930 Dump Truck Hoist Cylinders 46
D5B, D7G, D8K Tractor Sprocket Gaging 47
D7G Transmission Filter Reminder 48-49
130G Grader Cab Step 50
130G Grader Turbochargers 51

19-20

20



CBRN

52

Excess, Unserviceable Items Turn-in 52-53
M26 Decon Oil Usage 53

20

21

22

23

24-25

25

26



LOGISTICS MANAGEMENT

54

SMR Codes and Chart 54-59

SMR Codes and Chart

27-34

Connie's Post Scripts

60-61

You are invited to send PS your ideas for improving maintenance procedures, questions on maintenance and supply problems and questions or comments on material published in PS.

Just write to:

MSG Half-Mast
PS, the Preventive Maintenance Monthly
USAMC LOGSA (AMXLS-AM)
5307 Sparkman Circle
Redstone Arsenal, AL 35898

Or email to:

logsa.psmag@conus.army.mil or
half.mast@us.army.mil

Internet address:

<https://www.logsa.army.mil/psmag/pshome.cfm>

By order of the Secretary of the Army:

GEORGE W. CASEY, JR.
General, United States Army Chief of Staff

Official:

Joyce E. Morrow

JOYCE E. MORROW

Administrative Assistant to the Secretary of the Army

1026501

PS, The Preventive Maintenance Monthly (ISSN 0475-2953) is published monthly by the Department of the Army, Redstone Arsenal, AL 35898-5000. Periodical postage is paid at the Huntsville, AL post office and at additional mailing offices.

Postmaster: Send address changes to PS, The Preventive Maintenance Monthly, USAMC LOGSA (AMXLS-AM), 5307 Sparkman Circle, Redstone Arsenal, AL 35898-5000.

Issue 697

PS

December
2010

THE PREVENTIVE MAINTENANCE MONTHLY

TB 43-PS-697

Approved for
Public Release;
Distribution is
Unlimited

OBOY! HOME
IN TIME FOR
CHRISTMAS!

YEP! NEXT
WEEK WE'LL
BE DOING OUR
PMCS BACK
AT OUR OLD
HOME BASE.

THANKS TO GOOD
PM BY MY ELVES,
I'M GOOD TO GO ON
TONIGHT'S MISSION!

JOE
KUBER



WHEN YOU SEND IN AN INQUIRY TO PS...

...HELP US...

...HELP YOU!



Every day, we get questions from Soldiers and Army civilians about Army materiel. When you're stumped about equipment maintenance, a good bet is to contact PS. We have years of experience answering questions on maintenance and supply problems. If we don't know the answers, we usually know who does.

Now, help us help you.

- Regardless of how you contact us, we need your name, unit and phone number. If you want us to mail something to you, we need a full mailing address. And remember, some installations require the street address, not just the building number.
- Tell us what equipment, vehicle or weapon your question concerns. We need the model number with series.
- Give us the tech manual's number and its date, with changes that you're citing. If you have them, give us the NSN and its item and figure number.
- Be sure to enter a subject in the email's subject line.
- If our response to your question raises more questions, be sure to include the "JN" number (e.g., JN-39391/M) from our response in your return query. That can speed up our second response.

In a nutshell, we aren't looking over your shoulder and can't see what you see. And, we can't read your mind. Please don't leave us guessing!

THERE ARE FOUR WAYS TO SEND YOUR QUESTIONS AND SUGGESTIONS TO PS...



E-mail (we prefer this method):
logsa.psmag@conus.army.mil
 or half.mast@us.army.mil

Phone:
 DSN 645-0893,
 (256) 955-0893

Letter:
 USAMC LOGSA LEC
 ATTN: PS Magazine (AMXLS-AM)
 5307 Sparkman Circle
 Redstone Arsenal, AL 35898

Fax:
 DSN 645-0961,
 (256) 955-0961

PS THE PREVENTIVE MAINTENANCE MONTHLY

TB 43-PS-697, The Preventive Maintenance Monthly, is an official publication of the Department of the Army, providing information for all soldiers assigned to combat and combat support units and all soldiers with unit maintenance and supply duties. All information published has been reviewed and approved by the agency responsible for the equipment, publication or policy discussed. Application of the information is optional with the user. Masculine pronouns may refer to both genders. The use of product or company names does not constitute endorsement of those products, services or companies by the U.S. Army.

ISSUE 697 DECEMBER 2010

| | | | |
|---|-------|---|-------|
| COMBAT VEHICLES | 2 | AVIATION | 35 |
| Stryker Winch Pulley Lubing | 2 | UH-60, AH-64 Stabilator Covers | 35-37 |
| M1A1 Tank GPS Desiccant Assembly Cover | 3 | Aircraft Winter Maintenance Tips | 38-40 |
| M1-Series Tanks, Wolverine Road Arm Cracks | 4-5 | Fuel Handler Coverall NSNs | 40 |
| DSESTS Turn-in | 6-7 | | |
| Bradley AAL Addition | 7 | COMMUNICATIONS | 41 |
| AVLB Launcher Hydraulic Level Check | 8-9 | SINCGARS MT-6352/VRC Grounding Caution | 41 |
| M109A6 Engine Coolant Hose NSN | 9 | SINCGARS Antenna Offset Kit | 42-43 |
| M113A2-Series FOV Hydraulic Line Nut | 9 | Commo/Info System Cold Weather Reminder | 43 |
| | | Generator Fuel Tanks | 44-45 |
| WHEELED VEHICLES | 10 | SINCGARS External Antenna Connector | 46 |
| Stryker RWS, CROWS II Cover Differences | 10-11 | Battery Calculator Website | 46 |
| Wheel Assembly NSNs | 10-13 | | |
| Engine Cooling Systems PM | 14-16 | COMBAT ENGINEERING | 46 |
| Trailer Landing Leg AAL | 17-18 | M929, M930 Dump Truck Hoist Cylinders | 46 |
| M809-Series Tachograph Kit | 18 | D5B, D7G, D8K Tractor Sprocket Gaging | 47 |
| M939/A1/A2-Series Wheel Stud Nut | 18 | D7G Transmission Filter Reminder | 48-49 |
| | | 130G Grader Cab Step | 50 |
| MISSILES | 19 | 130G Grader Turbochargers | 51 |
| MLRS Wash Rack Cautions | 19-20 | | |
| | | CBRN | 52 |
| SMALL ARMS | 20 | Excess, Unserviceable Items Turn-in | 52-53 |
| M9 Bayonet Sharpening Stone | 20 | M26 Decon Oil Usage | 53 |
| Ammo Handling | 21 | | |
| M249 Machine Gun Gaging | 22 | LOGISTICS MANAGEMENT | 54 |
| Mortar Tube Danger | 23 | SMR Codes and Chart | 54-59 |
| M2 Machine Gun SRTA Requirement | 24-25 | | |
| M16 Rifle, M4/M4A1 Carbine Bolt Differences | 25 | | |
| LAR Assistance | 26 | | |

You are invited to send PS your ideas for improving maintenance procedures, questions on maintenance and supply problems and questions or comments on material published in PS.

Just write to:
MSG Half-Mast
PS, the Preventive Maintenance Monthly
USAMC LOGSA (AMXLS-AM)
5307 Sparkman Circle
Redstone Arsenal, AL 35898
 Or email to:
logsa.psmag@conus.army.mil or
half.mast@us.army.mil
 Internet address:
<https://www.logsa.army.mil/psmag/pshome.cfm>

By order of the Secretary of the Army:
GEORGE W. CASEY, JR.
 General, United States Army Chief of Staff

Official:

JOYCE E. MORROW
 Administrative Assistant to the Secretary of the Army
 1026501

PS, The Preventive Maintenance Monthly (ISSN 0475-2953) is published monthly by the Department of the Army, Redstone Arsenal, AL 35898-5000. Periodical postage is paid at the Huntsville, AL post office and at additional mailing offices. Postmaster: Send address changes to PS, The Preventive Maintenance Monthly, USAMC LOGSA (AMXLS-AM), 5307 Sparkman Circle, Redstone Arsenal, AL 35898-5000.

Stryker... Recovery's Easier With Working Winch

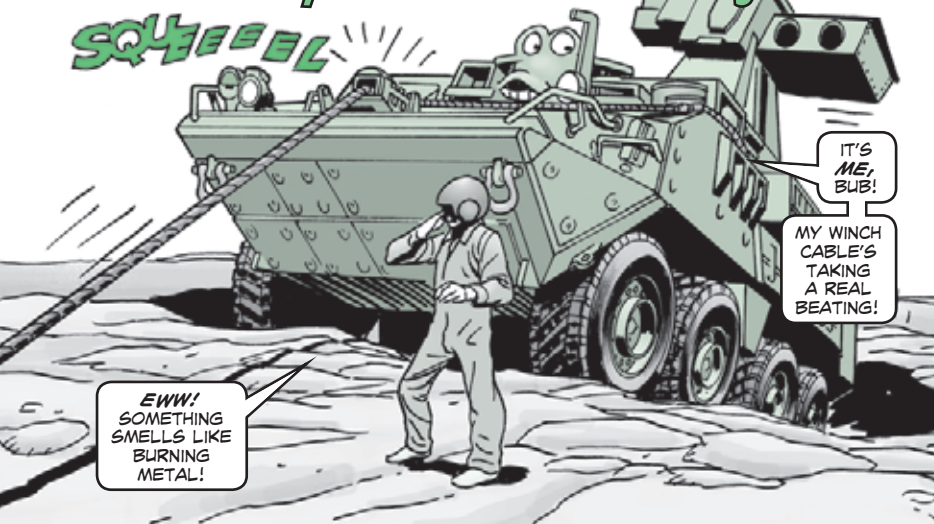

A loud SQUE-E-E-AL and the smell of burning metal aren't supposed to be part of recovery operations, drivers. 'Course, not lubing your Stryker's winch pulleys aren't exactly SOP, either.

Forget the lube and the pulleys can lock up. Then the winch cable is damaged by friction as it passes over the pulleys.

Keep those pulleys turning nice and smooth. A few pumps of GAA once a month will do the trick. Lubrication of the pulleys is covered under Item 5 of the monthly PMCS tables for all fittings and cable.

And when you're finished with recovery operations, leave a small amount of slack in the winch cable. That keeps the cable from rubbing against the corner of the front hatch when it's opened.

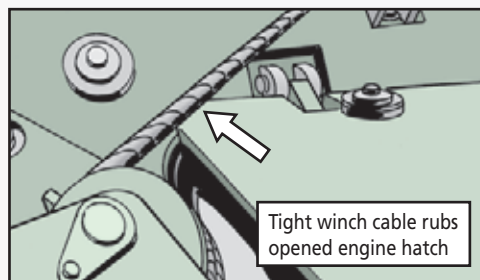
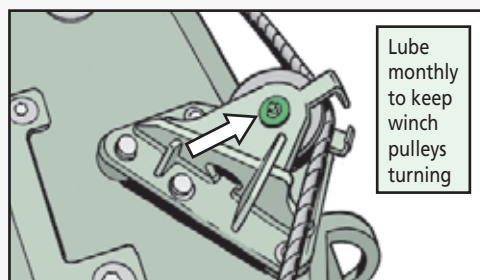

M1A1 Tank... EASY ON THE COVER SCREWS

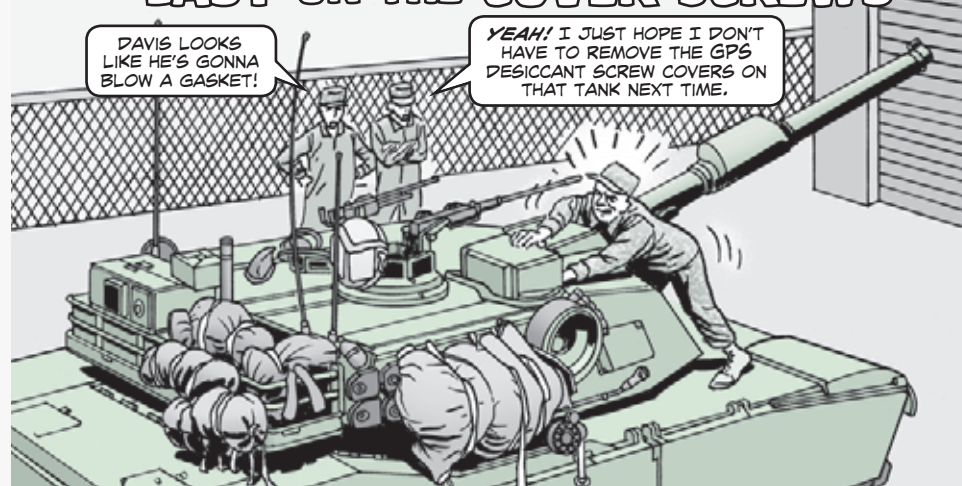

Mechanics, if your face is red and there's a big vein pulsing in your forehead, you're probably being a little heavy-handed with the desiccant assembly on the doghouse body of the gunner's primary sight (GPS).

When the desiccant is replaced, some of you are being especially rough on the cover screws, NSN 1240-01-267-8162.

If you screw in the covers too tight, the screw slots get chewed up. Your job just got a lot harder the next time the screw covers have to be removed.

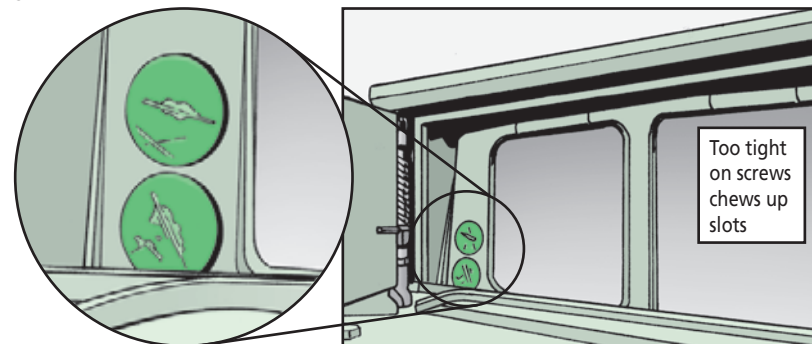

Inside both of the screws is an O-ring, NSN 5331-01-079-2931. It's the O-ring's job to keep the chamber pressurized, not yours.

So tighten the screw cover down, but not so much that you damage the slot. And it's a whole lot better for your blood pressure, too!

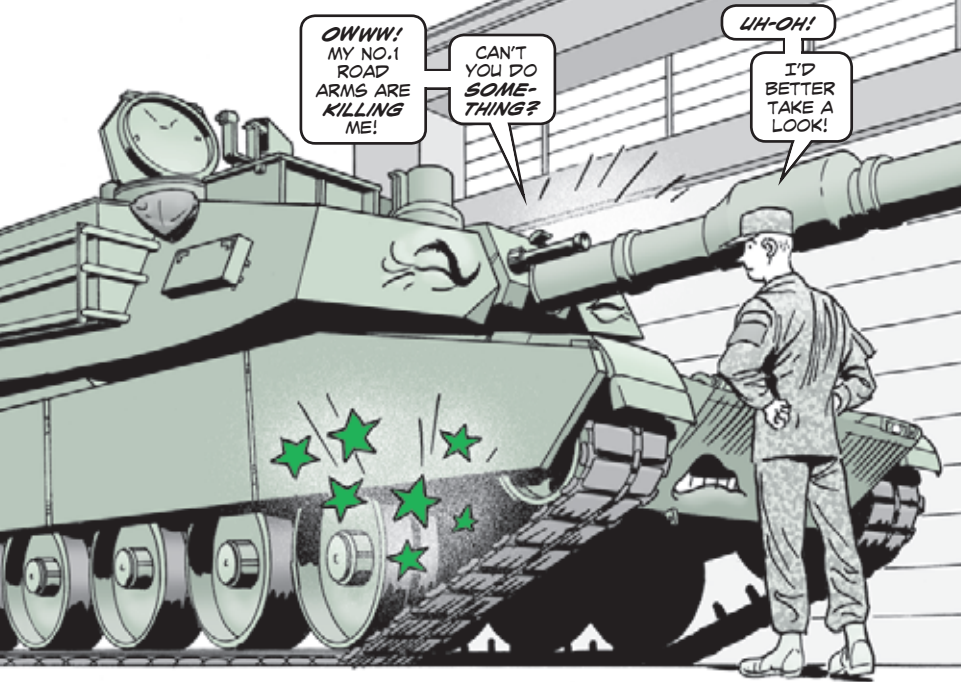

BEWARE THE CRACK ATTACK!

CREWMEN, THE LEFT AND RIGHT NO. 1 ROAD ARMS ON YOUR M1-SERIES TANKS AND WOLVERINE HEAVY ASSAULT BRIDGE SYSTEM TAKE A LOT OF STRESS.

SO MUCH, IN FACT, THAT SOME OF THOSE ROAD ARMS ARE STARTING TO CRACK.



The cracks often appear where the road arm connects to the track adjusting link. Analysis shows that the cracks result when loads absorbed by the No. 1 roadwheel are transferred to the connecting point between the road arm and track adjusting link.

In many cases, rust is present inside the cracks, a clear sign that the cracks have been there for some time. So far, there have been no road arm failures, but that doesn't mean they couldn't happen down the road.

To prevent a failure, inspect the No. 1 road arms on all of your vehicles immediately. Follow the PMCS procedures in your -10-1 TMs. Some of the cracks are very small and can be masked by paint on the road arm, so pay close attention to the connection point between the road arm and track adjusting link.

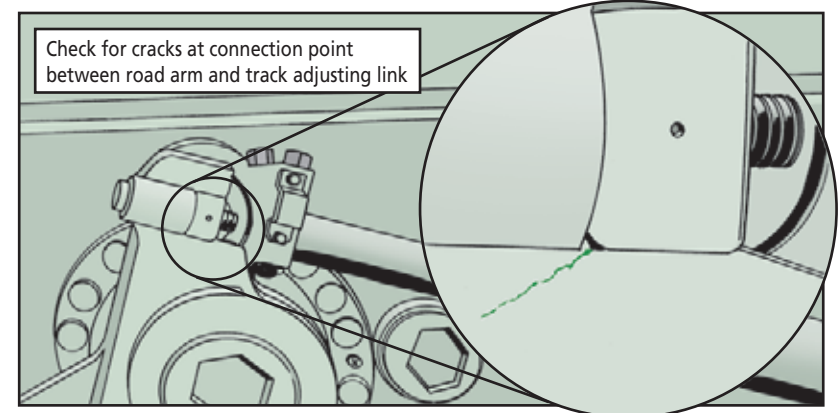

Find a crack? No matter how small it is, you should immediately order a replacement arm with a supply request priority of 05 N01 or higher. It's up to your commander to decide whether or not to allow limited operations until the replacement road arm arrives.

You should also get your mechanic to inspect the road arm to determine just how bad the damage is. If the vehicle stays in service, it's a good idea to place a mark at the end of each crack, forming a T. That way, you can tell if the crack is spreading by eyeballing the road arms during daily PMCS.

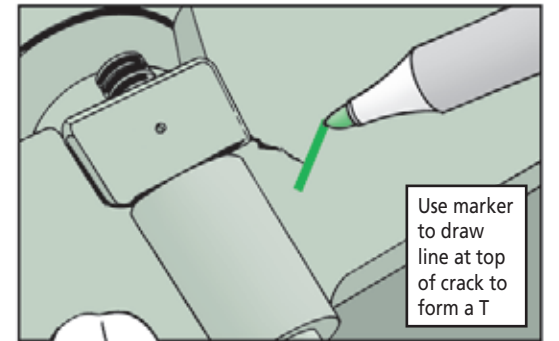

CHECK OUT THE COMPLETE SCOOP IN TACOM MAINTENANCE ACTION MESSAGE 10-034:
https://ae2s.ria.army.mil/commodity/mam/tacom_wn/ma10-034a.html

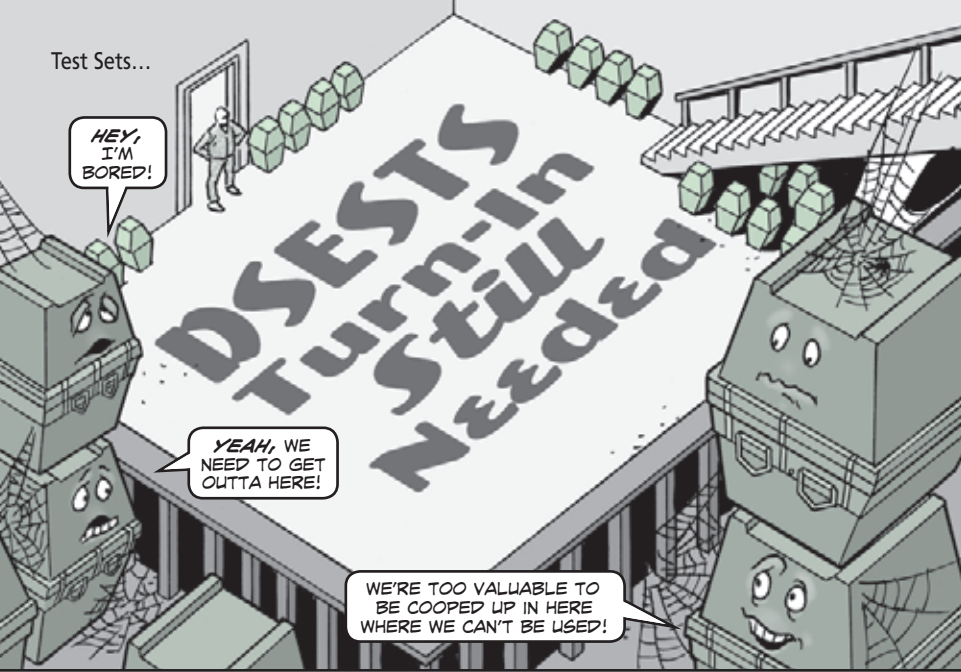

Units are forgetting to turn in their direct support electrical system test sets (DSESTS) when their mission ends or is transferred to another unit. That means the next unit given that mission can't do any DSESTS testing.

DSESTS was fielded to perform off-vehicle testing of line replaceable units (LRU) and shop replaceable units (SRU) from Bradleys and M1-series tanks. New DSESTS can't be ordered, so turn-in is vital.

A complete DSESTS comes in about 40 cases, along with additional equipment and fixtures. It consists of:

- General purpose interface assembly (GPIA), NSN 5998-01-382-7282
- Operator interface unit (OIU), NSN 6625-01-225-8342
- DSESTS common resources (DRC), which includes the common function modules, NSN 6625-01-443-2478, and combined support functions module (CFSM), NSN 6625-01-559-2662, or the enhanced unit, NSN 6625-01-569-3614
- M1 tank Legacy and Bradley A2 ODS Legacy, NSN 6625-01-120-0764 (LIN T52849)
- M1 thermal imaging system (TIS), NSN 4931-01-263-7972 (LIN T92250)
- M1A2 SEP, NSN 6625-01-376-0470
- Bradley TOW system, NSN 6625-01-442-7490
- Bradley A3, NSN 6625-01-453-7394
- Common FLIR TIS, NSN 6625-01-443-8390
- Wolverine, NSN 6625-01-474-5713

If you have any of this equipment, do the self-tests described in the 9-4931-586-series TMs to see if the equipment is serviceable.

Any DSESTS equipment that is listed on your unit's property book and is no longer required should be turned in through supply to your property book officer. This applies to serviceable as well as unserviceable equipment.

Any excess serviceable or unserviceable DSESTS equipment that is **not** on the unit's property book should be submitted through the Automated Excess Return Process using a document identifier code of FTE.

As excess DSESTS equipment is turned in, TACOM-Rock Island can then reissue it to units in need.

- Kevin Craft, DSESTS Equipment Specialist, DSN 793-0690, (309) 782-0690 or email: kevin.t.craft@us.army.mil
- Martin Spainhower, DSESTS Equipment Specialist, DSN 793-4836, (309) 782-4836 or email: martin.spainhower@us.army.mil
- Ken Jansen, DSESTS Equipment Specialist, DSN 793-2522, (309) 782-2522 or email: kenneth.jansen@us.army.mil
- Barry Tabron, DSESTS Weapon System Manager, DSN 786-7205, (586) 282-7205 or email: barry.tabron@us.army.mil

Bradley AAL Addition

Operators, get out your stubby pencils and make this addition to the additional authorization lists (AAL) for your M2A2/M3A2 and M2A3/M3A3 Bradleys, M3A3 BFIST, and M7 Bradley Fire Support Vehicles:

| NSN 5340-01- | Description |
|--------------|---|
| 537-8673 | Bradley Reactive Armor Tile (BRAT) Installation Kit (IK), PN 13011862 |
| 568-9668 | Bradley Reactive Armor Tile (BRAT) Installation Kit (IK), PN 13023500 |

Only one kit is required per vehicle. The two kits are identical except NSN 5340-01-537-8673 **does not** include the 96 8-in bolts required for mounting the tiles. This information will be added in a future change to TMs 9-2350-284-10-1 (May 03), 9-2350-294-10-1 (Nov 09), and 9-2350-297-10-1 (Sep 00).

AVLB...

**THAR'
SHE
BLOWS!**



Dear Half-Mast,

I'm confused about the annual requirement to check the AVLB's launcher hydraulic level. I've been told that you should check and fill the reservoir only when the bridge is installed on the vehicle.

Page G-5 of TM 5-5420-202-10 doesn't specify whether the bridge should be on or off. But it does show a drawing of the AVLB without the bridge.

What's the straight scoop?

SGT B.K.L.

Dear Sergeant B.K.L.,

You were told right. The bridge should be **on** the AVLB when checking the launcher's hydraulic fluid level.

If you bring the reservoir level to **FULL** with the bridge off, you'll be hearing cries of "Thar' she blows!" when you try to pick up the bridge. In other words, there'll be an FRH geyser coming out of the reservoir breather.

With the bridge on the vehicle, check the reservoir like this:

1. Unscrew the reservoir filler cap.

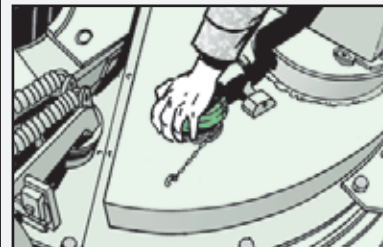

2. Remove the reservoir dipstick from the filler neck. Wipe it off with a clean cloth and reinsert it.

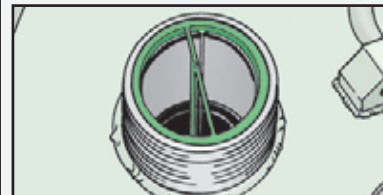

3. Remove the dipstick again and make sure the fluid level is at or slightly above the **FULL** mark.

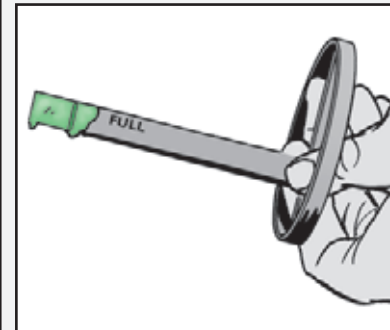

4. If the level is below the **FULL** mark, add FRH and start over again with step 2.

Half-Mast

M109A6 Engine Coolant Hose NSN

Order the bulk hose you need for your Paladin's engine coolant system using NSN 4720-01-088-1085 (PN A52426-1F). It replaces PN M62217/1-44, which is shown as Items 3, 12 and 27 in Fig 34 of TM 9-2350-314-24P-1 (Feb 99 w/Ch 4, Jan 09). That part number does not cross to an NSN.

M113A2-Series FOV Hydraulic Line Nut

Use NSN 5310-01-516-3969 (PN M45913/1-010CG8Z, CAGE 81349) to get a new loop clamp nut for the ramp hydraulic lines on your M113A2-series vehicles. It replaces NSN 5310-00-208-1918 (PN AN365-1024A, CAGE 88044), which is shown as Item 15 in Fig 314 of TM 9-2350-261-24P (Aug 05).

Stryker RWS and CROWS Covers **NOT** the Same!

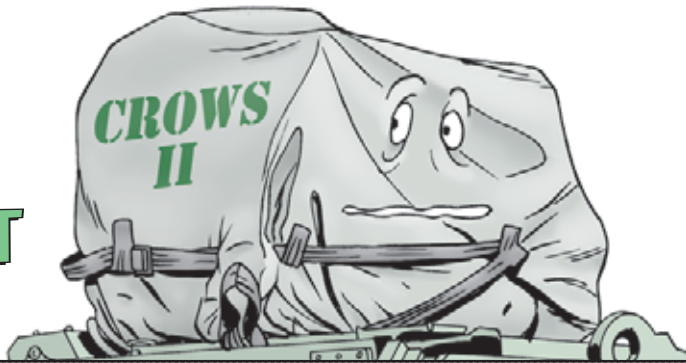

WE MAY *SEEM* INTERCHANGEABLE, BUT WE'RE *NOT!*

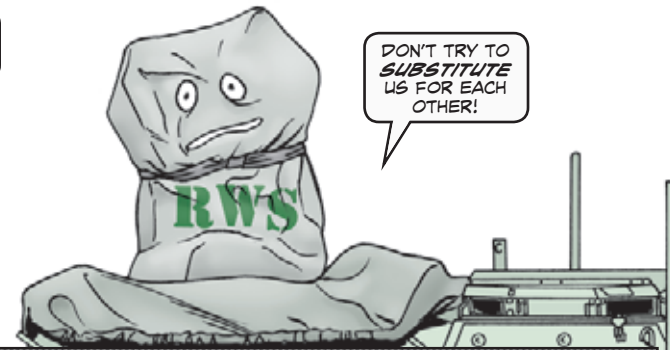

DON'T TRY TO *SUBSTITUTE* US FOR EACH OTHER!

Some units are ordering the Stryker RWS (remote weapon system) cover for the CROWS II cover or vice versa. They shouldn't, because these covers are **NOT** interchangeable. Order the green RWS cover with NSN 2590-25-150-4724. It's provided by General Dynamics Land Systems (GDLS) under their contractor logistic support agreement with PM Stryker. Order the tan CROWS II cover with NSN 5340-25-160-3971.

Got RWS cover questions? Contact Rich Harris at DSN 793-6481, (309) 782-6481, or email: richard.j.harris@us.army.mil

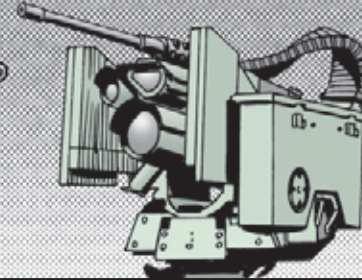
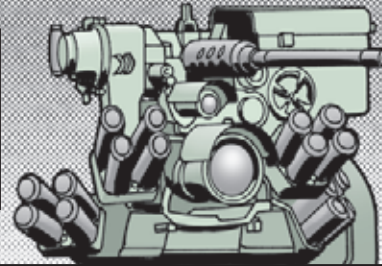

For CROWS II cover questions, contact Charlene McIntyre at DSN 793-7389, (309) 782-7389, or email: charlie.mcintyre@us.army.mil

Wheeled Vehicles...

TRANSITIONING FROM TIRE...

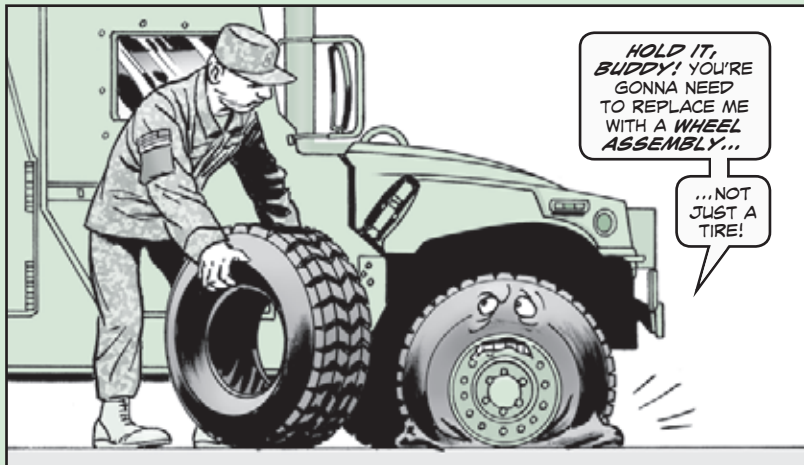

...TO WHEEL ASSEMBLY!

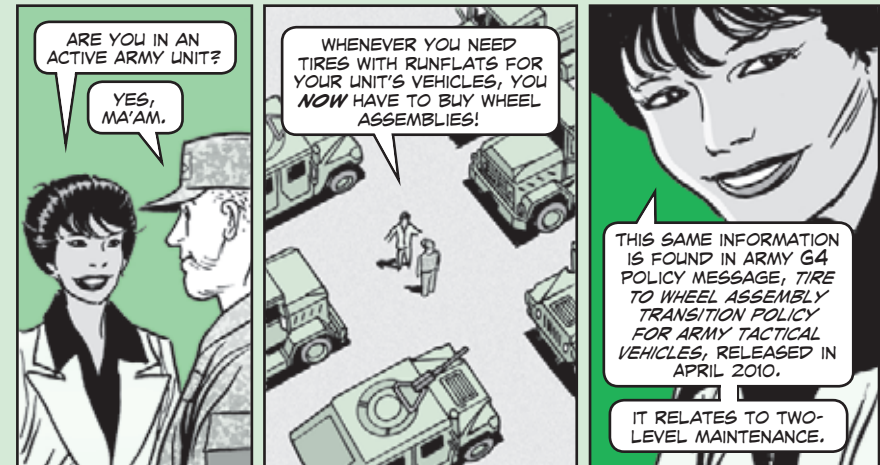



DA'S TIRE TO WHEEL ASSEMBLY TRANSITION PLAN HAS **TWO PHASES.**

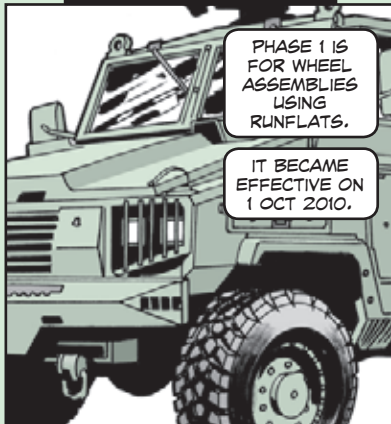

PHASE 1 IS FOR WHEEL ASSEMBLIES USING RUNFLATS.

IT BECAME EFFECTIVE ON 1 OCT 2010.

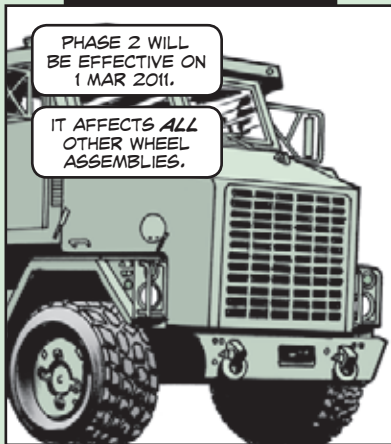

PHASE 2 WILL BE EFFECTIVE ON 1 MAR 2011.

IT AFFECTS ALL OTHER WHEEL ASSEMBLIES.



USE THIS TABLE TO ORDER WHEEL ASSEMBLIES WITH RUNFLATS...

| Vehicle | Wheel Assembly NSN 2530-01- |
|--|-----------------------------|
| M1117 ASV | 478-0593 |
| LAV | 532-5635 |
| Buffalo (front) | 535-9462 |
| Buffalo (rear) | 535-9459 |
| Buffalo (front for hull #'s 65-current) | 554-6621 |
| BAE RG33/RG33 HAGA | 555-4810 |
| BAE RG33/RG33 HAGA Plus | 563-0583 |
| BAE TVS Caiman | 555-4749 |
| BAE TVS Caiman Plus | 565-2137 |
| Navistar MaxxPro & MaxxPro Plus (front axle) | 555-5456 |
| Navistar MaxxPro (rear axle) | 565-5657 |
| Navistar Dash | 570-6352 |
| GDLS RG31 365 w/ steel rim | 560-8477 |
| GDLS RG31A2 365 w/ alum rim | 572-5907 |
| GDLS RG31A2 395 w/ alum rim | 572-5445 |
| FPII Cougar 6X6 | 537-3979 |
| FPII Cougar 4X4 | 563-7275 |
| HMMWV/M1101 trailer L/R D | 493-5859 |
| HMMWV/M1101 trailer L/R D (24-bolt rim w/ Michelin Baja/Goodyear MTR tire) | 558-2138 |
| HMMWV/M1101 trailer L/R E (24- or 20-bolt rim w/ Goodyear MTR tire/ Michelin Baja T/A) | 563-8620 |
| IMHEE (right) | 543-8303 |
| IMHEE (left) | 543-8304 |
| RG31 (MK2 and MK3) | 541-5364 |

USE THE TABLE ON PAGE 13 TO ORDER WHEEL ASSEMBLIES WITHOUT RUNFLATS...



| Vehicle | Wheel Assembly NSN 2530-01- |
|---|-----------------------------|
| M977 HEMTT w/o CTIS | 477-1660 |
| M1070/M1074/M1075 PLS/HET trucks w/ CTIS | 506-2715 |
| M1000 HET trailer | 506-5762 |
| M747 HET trailer radial | 506-5921 |
| M989A1 HEMAT trailer | 506-7324 |
| M1083/M1084/M1085 FMTV | 500-4619 |
| M923A1, M939A1, M939A2 | 506-7243 |
| M818/M926/M939 w/o ABS, M939 FOV | 506-7244 |
| M939 w/ABS | 506-8319 |
| M915A2 (front); M969, M969A1, and M969A2 semitrailers; M871 trailer | 506-4125 |
| M915A3 | 506-4128 |
| M915A4, M915A2 (rear); M871, M871A1, and M871A2 trailers | 506-4129 |
| M917A1 front | 506-4131 |
| M917A1 rear | 506-4132 |
| M916A1, M916A2 rear | 506-4133 |
| M916A3 (up-armored front) | 557-2625 |
| M916A3 (up-armored rear, right outer, left inner) | 584-7917 |
| M916A3 (up-armored rear, left outer, right inner) | 584-7915 |
| M920 | 506-4136 |
| M915A2 (up-armored) | 537-8294 |
| M915A3 (up-armored) | 537-8297 |
| M915A4 (up-armored) | 537-8299 |
| M878A2 | 514-5105 |
| M35A2; M200A1, M149A2, M105A2, and M332 trailers; M373A2, M313, M750 semitrailers | 506-5910 |
| M35A3 | 506-5915 |
| M1076 PLS trailer | 500-4991 |
| M860A1 Patriot trailer | 506-7315 |
| M870 trailer | 508-6677 |
| M870A1 trailer | 506-7646 |
| M870A3 trailer | 571-7223 |

| Vehicle | Wheel Assembly NSN 2530-01- |
|--|-----------------------------|
| M1062 trailer | 506-7648 |
| M172A1 trailer | 506-7650 |
| M129A4 semitrailer | 514-7903 |
| M1061A1 trailer | 514-7909 |
| M119A2 (left side) | 541-7004 |
| M119A2 (right side) | 541-7001 |
| FMTV trailer | 542-7405 |
| M871, M871A1, M871A2 semitrailers | 506-4129 |
| M871A3 semitrailer | 508-2786 |
| M872 trailer series | 547-4136 |
| M872A4, M871R, M871A1R, M871A2R, M871A3R | 584-7914 |
| M200A1 trailer | 528-9461 |
| M967A2, M969A3 | 527-4609 |
| 10K ATLAS forklift - right | 446-1035 |
| 10K ATLAS forklift - left | 514-8514 |
| 4K RTFL (JI case M4K) | 506-6873 |
| M10A 10K (right side) | 506-6884 |
| M10A 10K (left side) | 527-9583 |
| 50K RTCH (Caterpillar) | 506-6885 |
| 50K RTCH (Kalmar) | 484-1419 |
| 6KVRRTFL (right side) | 518-3656 |
| 6KVRRTFL (left side) | 518-3659 |
| 130G grader (right side) | 549-6588 |
| 130G grader (left side) | 582-3904 |
| MW24C (right side) | 581-5782 |
| MW24C (left side) | 584-7913 |
| CS-563D vib roller | 572-7187 |
| SEE | 527-9584 |



BY THE WAY, ONLY APPROVED TIRE ASSEMBLY REPAIR SITES WILL BE ABLE TO GET TIRES SEPARATELY.

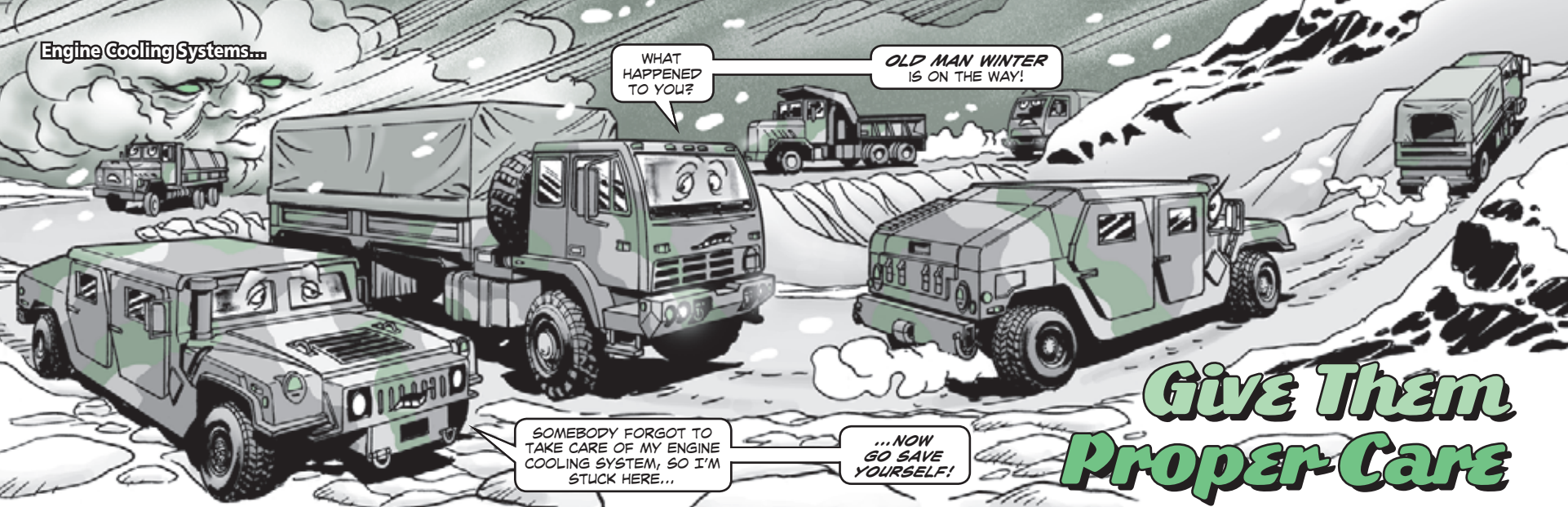

Give Them Proper Care



Your vehicle's cooling system should be able to reach 160-180°F in all temperatures. If it doesn't, get a mechanic to check the thermostat. It may need replacing.

A vehicle system that always runs at more than 200°F also needs attention. A broken thermostat, a clogged radiator, a bad radiator cap or filthy coolant may be the culprit. The engine's air flow may even be blocked.

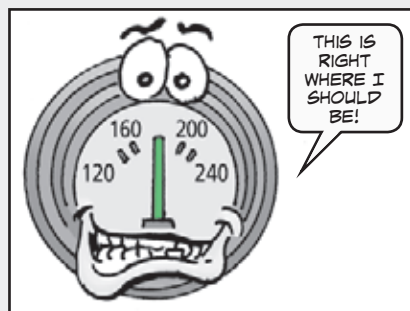

To speed up heating in freezing weather, you can partially cover the air intake grilles with tarp when starting the vehicle. But remember to remove the cover after the engine reaches operating temperature.

Look at the radiator cap. It should be the one your TM calls for. Just any cap won't do. The pressure rating of the cap is vital. Too low a rating lowers the boiling point of your coolant. Too high a rating builds up pressure that'll pop radiator seams or blow out hoses.

Hoses must withstand heat, pressure and vibration. They're rubber, so they rot, harden and crack with age. That's why you need both *eyes and hands* to detect bad hoses. Bad hoses are puffy, hard, mushy, or wet. Report them.

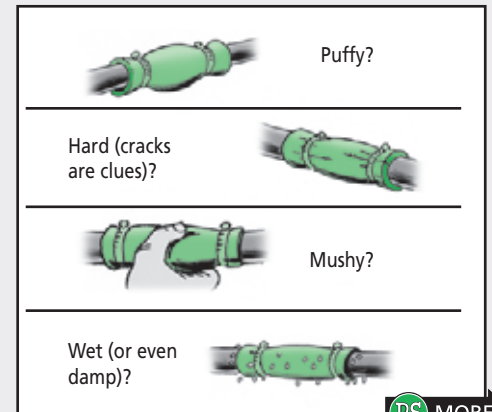
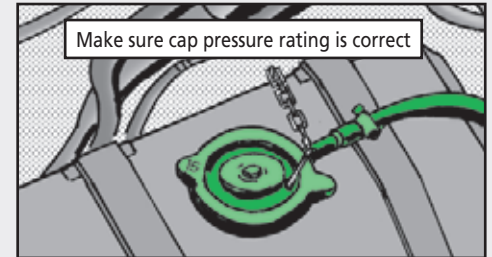

Check the radiator. Look for leaks on the top, front, back and bottom.

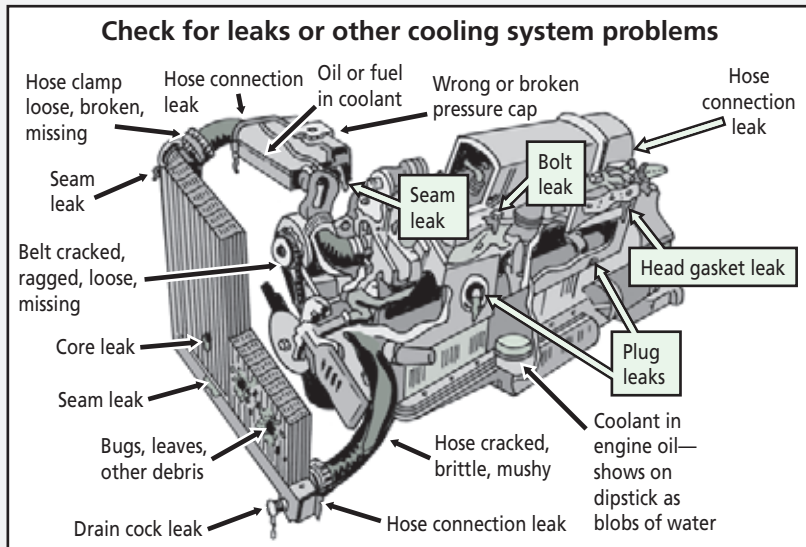

Leaks may not show up when your engine is cold, so look for rust and odd-colored dribbles where coolant has leaked and dried.

Later, when you've got the engine running at operating temperature and pressure, check those places again for wet spots. Use a flashlight during both inspections.

Finally, take the radiator cap off carefully. If the cooling system is hot, open the filler cap slowly until all pressure is gone. But be sure to use a rag or glove to protect your bare hand from a hot cap or hot coolant.

The coolant should be a little over the top of the core. It should be almost clear—and colored by the antifreeze.

If your coolant is muddy-looking or has bits of gunk in it, your cooling system needs draining and flushing, and maybe even cleaning. Report it.

If you see a rainbow of oil slime on top of the coolant, you probably have a leak inside the engine. Exhaust gas or oil is getting into your cooling system. Pull the crankcase dipstick and check for water in the oil. Little blobs of water will show on the dipstick. Report any slime or blobs that you see.

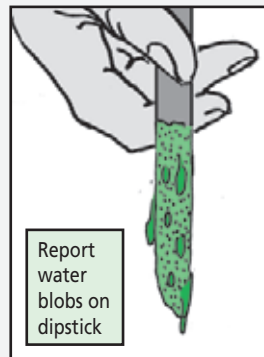

Drivers, air-cooled systems don't need much attention. All they need is a good flow of air. That means all the airflow shrouds must be in place.



M105A2/A3, M149A2 and M200A1 Trailers...

AAL and Replacement Landing Leg

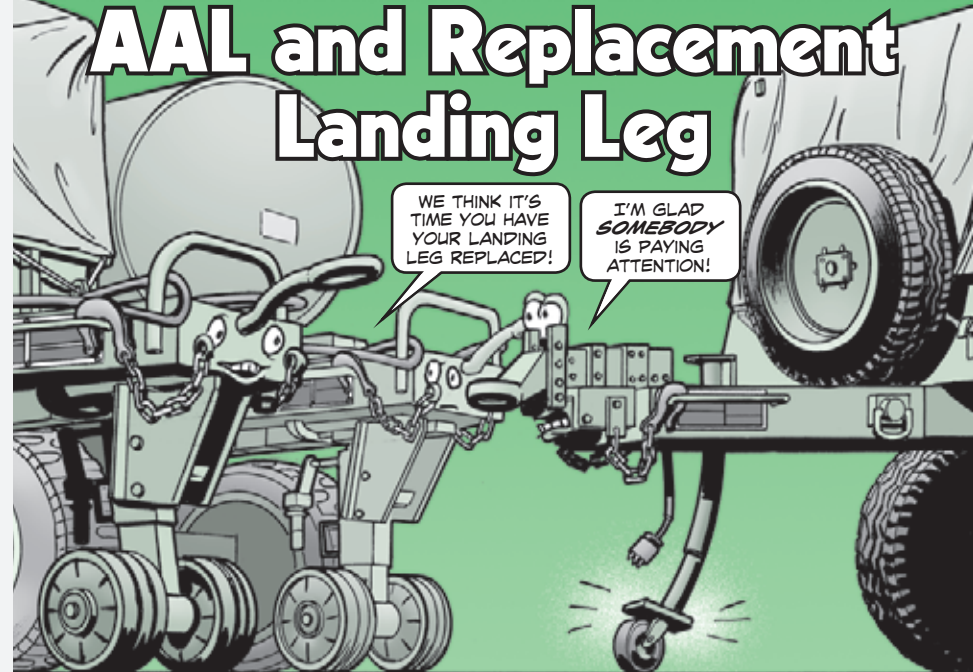

NEED THE LATEST CHANGES RELATED TO YOUR M105A2, M105A3, M149A2, AND M200A1 TRAILERS?

KEEP READING TO GET AN AAL UPDATE AND THE LATEST INFO ON LANDING LEGS.

Additional Authorization List (AAL)

For M105A2 and M149A2 trailers:

Get your commander's approval to replace the original lunette with a swivel lunette that comes with NSN 2540-01-557-0056.

The swivel lunette on these trailers makes lining up the trailer with the truck's towing pintle a whole lot easier—especially in rough terrain or bad weather. Just mount the new lunette into the old lunette's recess.

NSN 2540-01-557-0056 gets swivel lunette

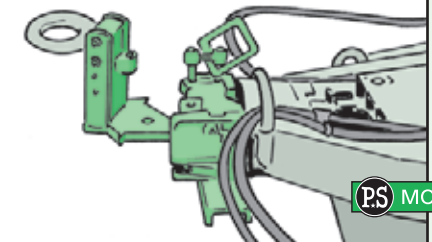

And it's no secret that the landing legs on both trailers are tough to raise and lower. Get a landing leg assist lever with NSN 5340-01-557-0024. The added leverage makes raising and lowering the legs easier. It can be released from its locked position in one motion. Plus, the assist lever fits into position without drilling or modifications.

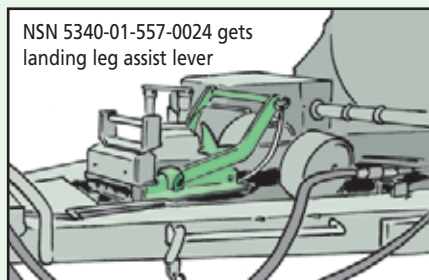

NSN 5340-01-557-0024 gets landing leg assist lever

For M200A1 trailers:

You know how hard it is to raise and lower the M200A1 trailer's landing leg into position. Tired of getting down on the ground, smashing your fingers and scraping your knuckles? Then get the jack support platform with NSN 4910-01-571-8444. It works with levers, making raising and lowering the leg easier.

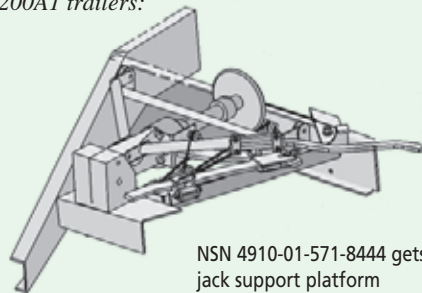

NSN 4910-01-571-8444 gets jack support platform

Replacement Landing Leg

For M105A3 trailers:

TACOM LCMC's GPA 09-019 tells users to replace original model landing legs on M105A3 trailers with new ones. These stronger and safer landing legs come with NSN 2590-01-564-2057 and are provided with MWO 9-2330-324-23-1. Eyeball this message online for more details:

https://aeaps2.ria.army.mil/commodity/gpm/tacom_wn/gpm09-019.html



M809-Series Tachograph Kit

To get a new electronic tachograph kit for an M809-series 5-ton truck, use NSN 6680-01-567-7851. The gauge that comes with the kit is available separately with NSN 6680-01-572-2254. This kit replaces the old mechanical tachograph shown as Item 8 in Fig 521 of TM 9-2320-260-24P-2.

M939/A1/A2-Series Wheel Stud Nut

To get the wheel stud nut for the M939/A1/A2-series 5-ton truck, use NSN 5310-01-445-6872. This replaces NSN 5310-01-102-2711, shown as Item 7 in Fig 292 of TM 9-2320-272-24P-1.

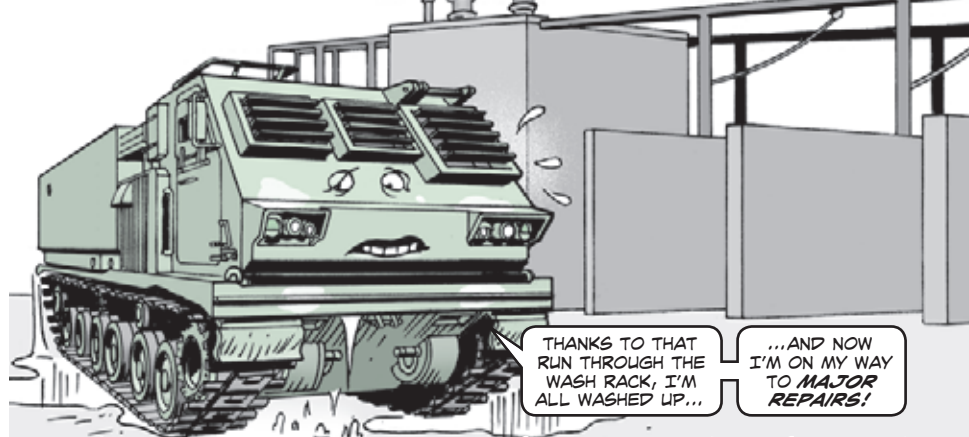

THANKS TO THAT RUN THROUGH THE WASH RACK, I'M ALL WASHED UP...

...AND NOW I'M ON MY WAY TO MAJOR REPAIRS!

Don't Leave MLRS Washed Up!

Cover all line replaceable units (LRUs) with a tarp or plastic before you go through a wash rack.

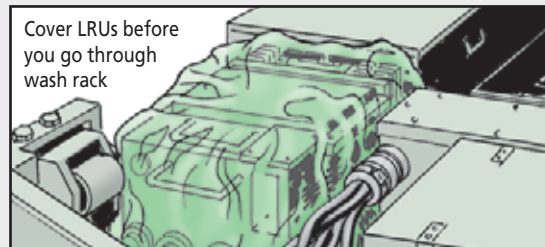

Cover LRUs before you go through wash rack

LOTS OF MLRS ELECTRONICS ARE BEING DAMAGED BECAUSE CREWS AREN'T PAYING ATTENTION TO WASHING DO'S AND DON'TS.

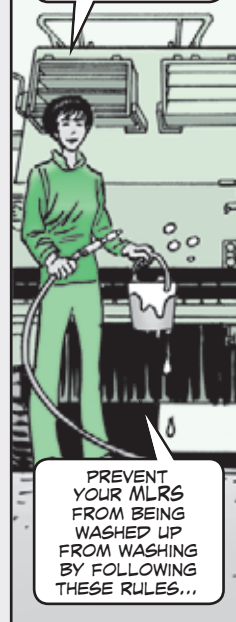

PREVENT YOUR MLRS FROM BEING WASHED UP FROM WASHING BY FOLLOWING THESE RULES...

Don't use high pressure water or steam to clean the inside or the rear of the launcher or in the carrier vehicle bed. High pressure water can force its way inside high-dollar electrical equipment like LRUs. The water causes electrical shorts, corrodes connectors and receptacles, ruins circuit cards, and just generally wrecks all kinds of expensive damage.

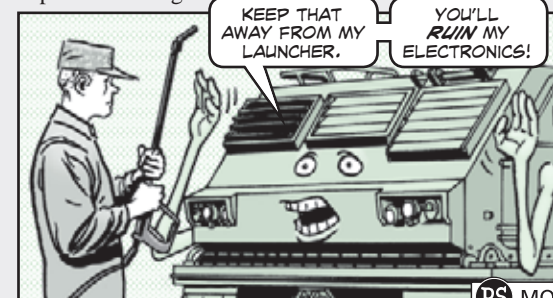

KEEP THAT AWAY FROM MY LAUNCHER.

YOU'LL RUIN MY ELECTRONICS!

Clean the inside of the launcher with soap and water. Use a water spray at normal tap pressure to clean the interior and rear of the launcher, the carrier vehicle bed and the equipment mounted in it. Rinse with clean water from a bucket. Make sure the drain valves are open so the water can drain out.

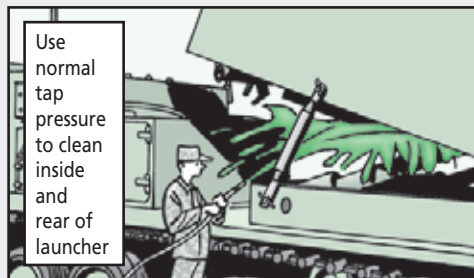

Don't use brushes on electrical components. That can loosen their connectors, which lets water seep in the components. Wipe them clean with a damp—not soaking wet—cloth. Be careful not to get water into electrical components.

Check the carrier's air filter canister after you go through the wash rack. A water-clogged filter won't let air through to the engine, which quickly kills the engine. If the filter is damp, let it air dry thoroughly before you run your MLRS again.

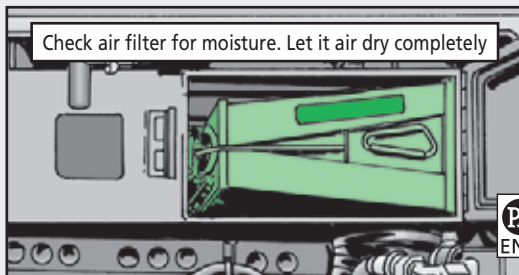

M9 Bayonet...

REPLACING SHARPENING STONE

I JUST HAVEN'T FELT VERY SHARP LATELY.

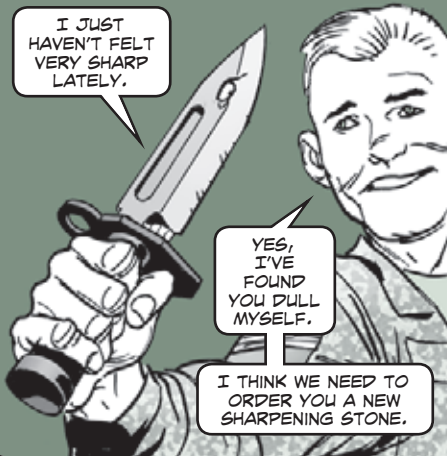

Dear Half-Mast,
Where do you get a replacement sharpening stone for the M9 bayonet?

LT T.W.

Dear Lieutenant T.W.,
The sharpening stone for the M9 was removed some time ago. If you need to sharpen the bayonet, use the sharpening stone from the small arms repair tool kit. Or you can order a new stone with NSN 5345-00-243-6086 or local purchase one.

Half-Mast

Small Arms...

Handle Ammo with Care... ... Or Else!



Machine gun and rifle ammo are designed to do serious damage to the enemy, but they can do serious damage to you if **you** don't handle them with care. Several Soldiers have learned that lesson the hard way.

A cartridge is not a substitute for a tool. Sometimes Soldiers try to use a .50-cal cartridge to hammer out mounting pins. Very bad idea! Or when a round won't fit in a linked ammo belt, they try to hammer it in place with a multi-purpose tool. Whoa!

Cartridges have a primer that is impact sensitive. When the primer is struck by **any** hard object, it will ignite. Most small arms ammo propellant generates 50,000 to 60,000 psi when ignited. If a cartridge is not enclosed within the steel barrel of a weapon when it fires, it is like a small hand grenade. You don't want it near your hands or body when it goes off.

So handle ammo cartridges with care. Don't throw ammo around. Never use a cartridge as a hammer and never hammer on a cartridge.

STRAIGHT TALK ON STRAIGHT GAGING



I'M GONNA USE THIS STRAIGHTNESS GAGE TO CHECK YOU OUT!

HEY, I DON'T NEED THAT!

SAVE IT FOR RIFLES AND CARBINES!

Dear Half-Mast,
I have always dropped a 5.56mm straightness gage through all my M249 machine gun barrels to check that they're OK. But I don't see anything in the M249 TM about doing this. Should I be doing this check?
SPC D.R.

Dear Specialist D.R.,
No, you don't need to do a check with the straightness gage. That gage is to be used only for the M16 rifle and M4 carbine. Because of the differences in rates of fire between the M249 and the M16/M4, there are different barrel wear patterns. As a result, the gage might not pass through an M249 barrel that's still OK for firing. The only gaging required for the M249 is for breech bore erosion, trigger pull, headspace and firing pin protrusion.

If you have questions about this, contact Matt Williams at DSN 793-1918, (309) 782-1918, or email: matthew.williams22@us.army.mil
Or, contact Andre Pilgrim at DSN 793-7458, (309) 782-7458, or email: andre.pilgrim@us.army.mil

Half-Mast

MORTAR TUBE DANGER!

LISTEN UP!

A BAD BATCH OF CANNON TUBES FOR THE M120/M121 MORTAR HAS GOTTEN OUT TO THE FIELD.



These tubes might contain cracks in the cannon wall that can't be found through normal field-level inspection, but only through a depot-level check. Using the bad tubes has already been fatal, which is why all mortar units should immediately check their cannon tubes for these serial numbers:

- 11451
- 11458
- 11467
- 11476
- 11481
- 11488
- 11526
- 11529
- 11531
- 11536
- 11539
- 11546
- 11554
- 11601
- 11729
- 11737

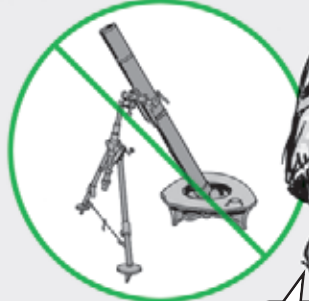

IF YOU FIND ANY M120/M121 CANNON TUBES WITH THESE SERIAL NUMBERS, **DON'T USE THEM.**

NOTIFY YOUR LOCAL TACOM LOGISTICS ASSISTANCE REPRESENTATIVE. HE WILL HELP YOU TURN IN THE TUBE FOR A REPLACEMENT.

As always, operators should perform their mortar's PMCS and before firing checks. Units also need to keep their DA Form 2408-4, *Weapons Record Data Cards*, current and make sure cannon tubes have been borescoped and pullover inspected before any live firing.

For more information on M120/M121 mortars, contact TACOM's Joe Schmidt at DSN 786-8783, (586) 282-8783, or email: joe.schmidt@us.army.mil

Also see TACOM LCMC SOUM 10-021 and 10-027.

M2 Needs M3 for SRTA

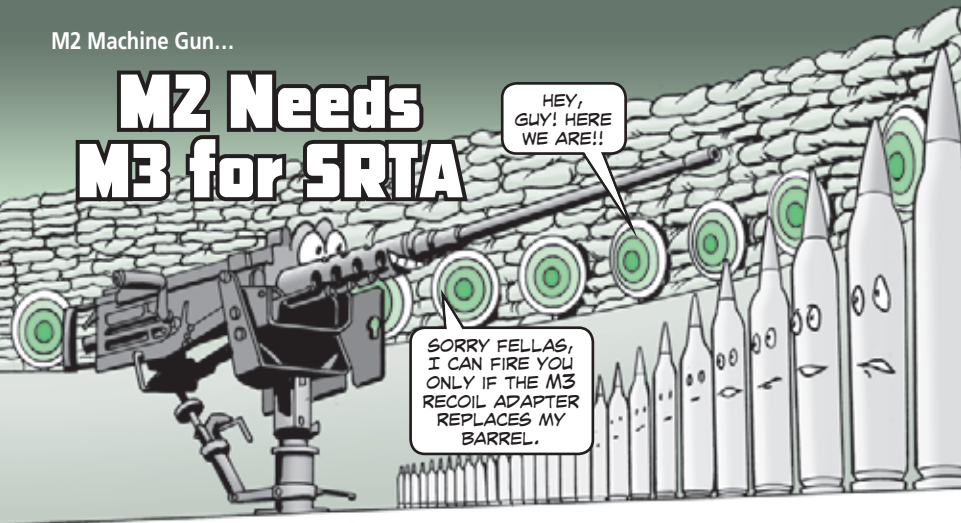

If you have limited space for training with your M2 machine gun, short range training ammunition (SRTA) is a great solution.

Normal .50-cal ammo requires a surface danger zone impact area of 6,500 meters. But .50-cal SRTA (DODICs A602 and A603) requires an impact area of only 700 meters.

But SRTA isn't great if you don't use the M3 recoil amplifier. If you don't use the M3 recoil amplifier with the M2 when firing SRTA, there's not enough back pressure to keep the M2 firing. It fires once and stops.

The M3 screws into the M2 the same way the normal barrel does. Everything you need to know about the M3 is in TM 9-1005-203-13&P (Oct 09), which is on the ETM Online site: <https://www.logsa.army.mil/etms/online.cfm>. You get the M3 from your local training support center.

When you install the M3, make sure the discriminator is properly installed in place of the front cartridge guide. That ensures normal live ammo can't be fired.

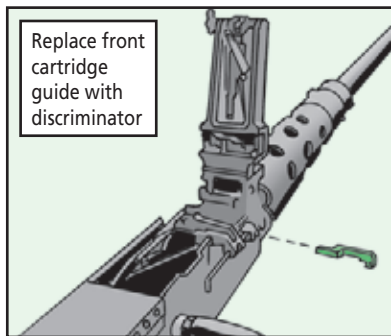
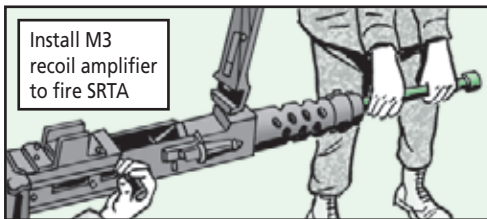

Before firing SRTA, make sure only M858 ball or M860 tracer SRTA is in the linked belt. Don't try to fire SRTA that is dented, deformed or has a loose projectile. Firing standard ammo or damaged SRTA can injure you and damage the M2.

Remember SRTA is as lethal as standard ammo. Don't use SRTA for MILES, paintball, or force-on-force training. **SRTA is strictly for firing at inanimate targets.**

Reduced range ammo doesn't mean reduced noise, explosive hazard or potential injury or death. Wear eye and hearing protection and practice normal safety rules when firing SRTA.

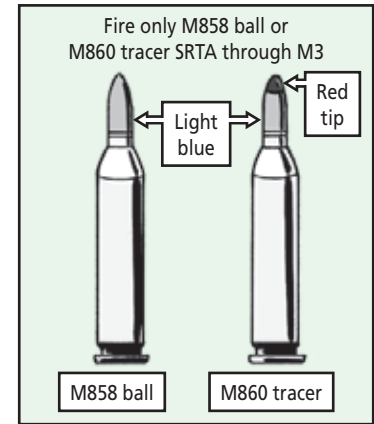

M16-Series Rifle, M4/M4A1 Carbine...

ARE THERE DIFFERENT BOLTS?

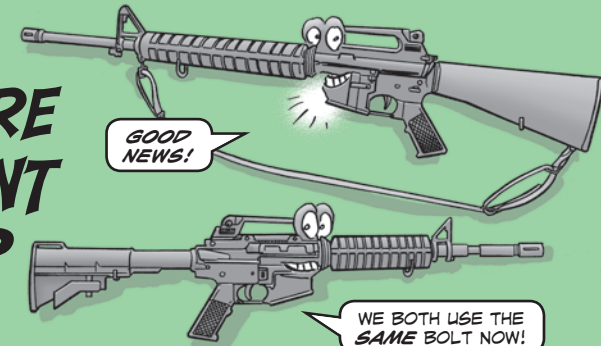

Dear Half-Mast, TM 9-1005-319-23&P lists separate bolt NSNs for the M16 rifle and M4/M4A1 carbine. Are there differences in the bolts? Are you not supposed to use the M16 bolt in the M4 or vice versa?

D.A.

Dear Mr. D.A.,

Originally, the M16 and M4 bolts used different extractor springs. But that's no longer true. Now both weapons use the same breech bolt assembly, NSN 1005-01-505-1035, and the same extractor spring assembly, NSN 5360-01-505-2886, which is gold-colored. If you still have bolts with the old extractor assembly, which is silver-colored, continue to use them. But when their extractors wear out, order the gold extractor.

TM 9-1005-319-23&P (May 05) lists two separate bolts, but the November 08 edition correctly lists just one.

Half-Mast

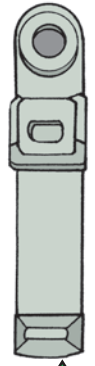

Order only gold extractor spring, NSN 5360-01-505-2886

Armorers, Use Your LAR



I DON'T REALLY KNOW IF I SHOULD BE PUTTING THIS SCOPE ON YOU.

I WONDER HOW I COULD FIND OUT FOR SURE.

OUR LARS WOULD KNOW.

LET'S GIVE 'EM A RING!

Dear Editor,

I repair small arms in the Ft Hood DOL. We often encounter armorers who are having problems and are unaware of one of the best resources available: the TACOM logistics assistance representative (LAR).

The TACOM armament LAR can answer questions about:

- what is authorized to be put on weapons
- what MWOs are required and how to get them done
- items that are unclear or contradictory in the TMs
- changes to the TMs that haven't been published yet
- why there are different NSNs for the same part
- how to request or turn in weapons

Almost every post has a TACOM armament LAR who usually can answer these types of questions immediately. The warrant officer who runs your support shop knows who your TACOM armament LAR is, as does your small arms DOL repairmen.

Elton Kloesel
DOL
Ft Hood, TX

Editor's note: Excellent advice, Elton. You can also find your local LAR through the worldwide logistics support element locator:
<https://aeps2.ria.army.mil/services/lars/laocator/laomap.cfm>
 Or contact TACOM's Michael Mumford at DSN 786-6140, (586) 282-6140, email michael.mumford1@us.army.mil

THE NIGHTMARE BEFORE PMCS

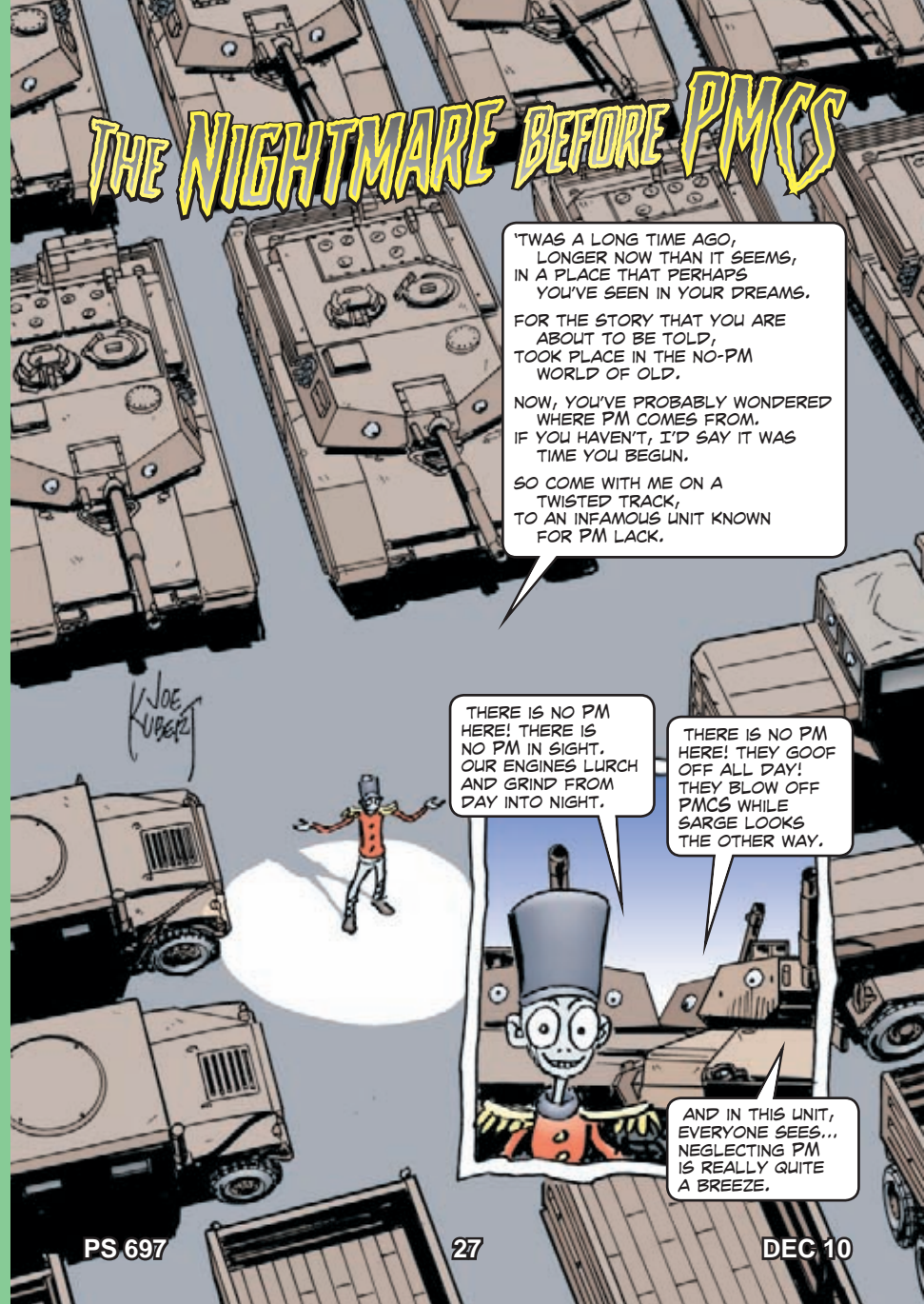

'T WAS A LONG TIME AGO, LONGER NOW THAN IT SEEMS, IN A PLACE THAT PERHAPS YOU'VE SEEN IN YOUR DREAMS. FOR THE STORY THAT YOU ARE ABOUT TO BE TOLD, TOOK PLACE IN THE NO-PM WORLD OF OLD.

NOW, YOU'VE PROBABLY WONDERED WHERE PM COMES FROM. IF YOU HAVEN'T, I'D SAY IT WAS TIME YOU BEGUN.

SO COME WITH ME ON A TWISTED TRACK, TO AN INFAMOUS UNIT KNOWN FOR PM LACK.

JOE SUBERZ

THERE IS NO PM HERE! THERE IS NO PM IN SIGHT. OUR ENGINES LURCH AND GRIND FROM DAY INTO NIGHT.

THERE IS NO PM HERE! THEY GOOF OFF ALL DAY! THEY BLOW OFF PMCS WHILE SARGE LOOKS THE OTHER WAY.



AND IN THIS UNIT, EVERYONE SEES... NEGLECTING PM IS REALLY QUITE A BREEZE.



BUT I AM THE BRAKES HIDING BEHIND THESE WHEELS... PADS WEARING THIN AND MAKING SCARY SQUEALS!

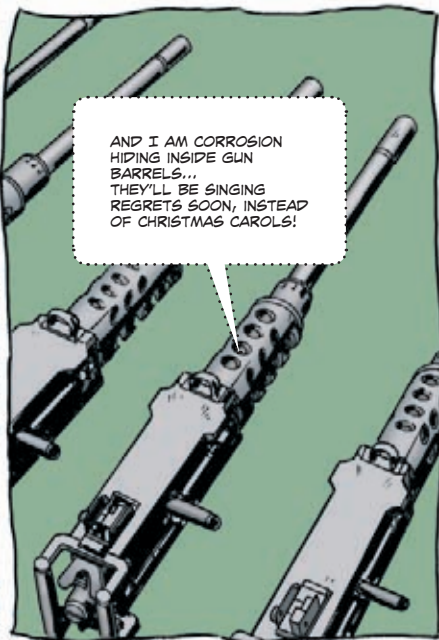

AND I AM CORROSION HIDING INSIDE GUN BARRELS... THEY'LL BE SINGING REGRETS SOON, INSTEAD OF CHRISTMAS CAROLS!

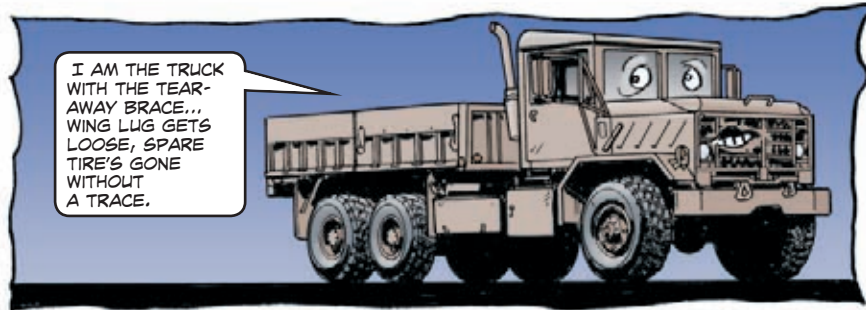

I AM THE TRUCK WITH THE TEAR-AWAY BRACE.. WING LUG GETS LOOSE, SPARE TIRE'S GONE WITHOUT A TRACE.



I AM THE "WHAT" WHEN THEY SAY, "WHAT'S THAT SOUND?"



IN THIS UNIT I CALL HOME BASE... MY RUSTY ROADWHEEL BETRAYS THIS NO-PM PLACE.



BUT IN THIS UNIT THEY JUST CLOWN AROUND... NO MATTER HOW MUCH I SCOLD AND HOUND!

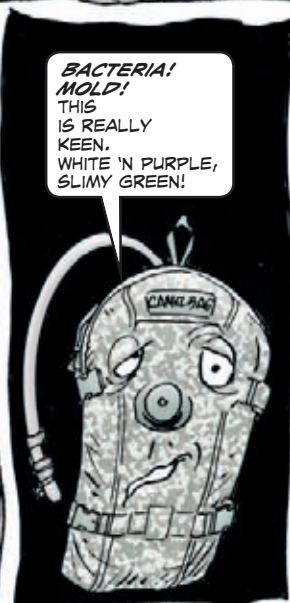

BACTERIA! MOLD! THIS IS REALLY KEEN. WHITE 'N PURPLE, SLIMY GREEN!



AND I AM THE SHOCK WHEN SOMEONE FORGETS TO GROUND!



WHILE OUR PARTS TURN RUSTY-BROWN...

...READINESS RATINGS ARE SURE GOING DOWN!



I SENSE THERE'S SOMETHING IN THE WIND... THAT FEELS LIKE DANGER'S IN THIS MIX. THOUGH I HOPE I'M WRONG THIS TIME... WHAT NIGHTMARES MAY COME BY FAILING TO FIX?

DON'T THEY NOTICE HOW EVERYTHING'S FAILING?

DON'T THEY KNOW HOW *DANGEROUS* IT CAN BE?

YES, I THINK THEY HAVE BLINDERS ON... NO, I FEAR THEY DON'T EVEN SEE!

ALTHOUGH I'D LIKE TO JOIN THIS CREW IN THEIR ENTHUSIASTIC SLACK... TRY AS I MAY, I DREAD KARMA'S PAYBACK.

DOLLY WAS RIGHT TO BE WORRIED. THAT FATEFUL DAY CAME WHEN THE BRAKES FAILED ON THE UNIT'S HEAVY CARGO TRUCK.

THREE SOLDIERS GOT HURT IN THE TERRIBLE CRASH. MOST IN THE UNIT DIDN'T THINK ABOUT IT TOO MUCH.

FOR EVERYONE SAID, "T'WAS JUST AN ACCIDENT!"



BUT IT BOTHERED ONE MECHANIC NAMED JACK AND MADE HIM REVIEW THE HARM A NO-PM CREED CAN DO.

FOR T'WAS HE WHO HAD SKIPPED PMCS ON THE TRUCK WHOSE BRAKES HAD FAILED.

HE WANTED HIS WAYS TO MEND. SO, DESPITE HIS CAREFREE FRIENDS, HE TOOK UP THE CAUSE FOR PM!



I'VE READ THESE TMS SO MANY TIMES, I KNOW THE CHAPTERS AND I KNOW THE CHARTS...

I KNOW ALL THE WARNINGS BY HEART. MY BRAINS ARE SO FULL, IT'S TEARING ME APART!

I'VE READ THEM SO OFTEN, YET SOMETHING'S WRONG... IT'S HARD TO PUT MY GREASY FINGER ON.

OR PERHAPS IT'S REALLY NOT AS DEEP AS I'VE BEEN LED TO THINK... AM I TRYING MUCH TOO HARD?
OF COURSE! I'VE BEEN TOO CLOSE TO SEE THE ANSWER'S RIGHT IN FRONT OF ME.



YOU KNOW, I THINK THIS PM THING IT'S **NOT** AS TRICKY AS IT SEEMS... AND WHY SHOULD ANY LIVES BE LINDONE? PMCS SHOULD BE DONE BY **EVERYONE!**



NOT JUST ANYONE, IN FACT, BUT **ME**. WHY, I COULD HONOR **ALL** THOSE THREE...



SOMETHING'S UP WITH JACK, WHATEVER CAN IT BE? HIS GRIN IS EAR-TO-EAR AS YOU CAN PLAINLY SEE.

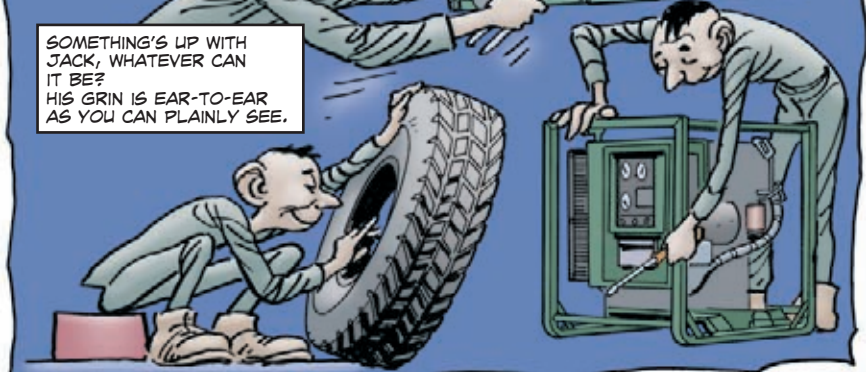

AND THERE'S NO REASON I CAN FIND I CANNOT HAVE A PM MIND.

I BET I COULD IMPROVE THIS UNIT, TOO. **AND THAT'S EXACTLY WHAT I'LL DO!**



WHISTLING TOO, WORSE THAN THE GUARDS... WORKING AGAIN, INSTEAD OF PLAYING CARDS.



DON'T KNOW WHAT'S UP, BUT IT'S CLEAR TO ME SOMETHING'S CHANGED AND MADE JACK HAPPY. I'M CURIOUS NOW, WHAT'S MAKING HIM TRY... HOLD ON NOW, I THINK I KNOW WHY!

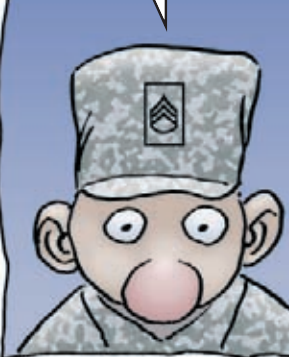

BY SETTING A GOOD EXAMPLE, JACK'S AFFECTED THE WHOLE CREW. EVERYONE'S STARTING TO PULL PMCS. HIS WORK ETHIC'S JUST LIKE GLUE!



SARGE'S HUNCH WAS RIGHT, AND SOON—THANKS TO JACK—THE UNIT BECAME KNOWN FOR ITS PM ATTACK!

AND SO WE'LL WORK TOGETHER,
NOW AND FOREVER...
FOR IT'S AS PLAIN AS ANYONE CAN SEE—
PMCS IS SIMPLY MEANT TO BE!



UH-60/
AH-64
Series...

PROTECT THE STABILATOR

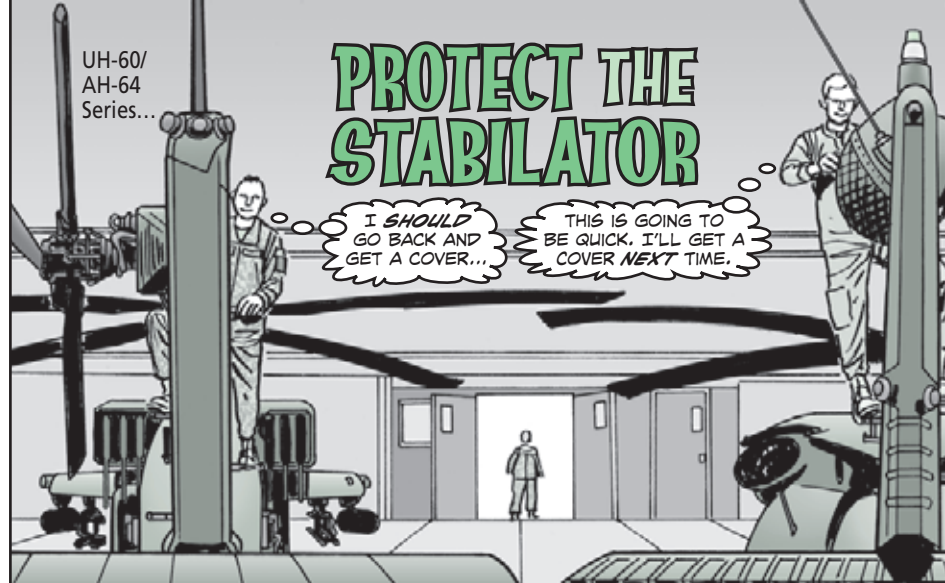

I *SHOULD*
GO BACK AND
GET A COVER...

THIS IS GOING TO
BE QUICK. I'LL GET A
COVER *NEXT* TIME.

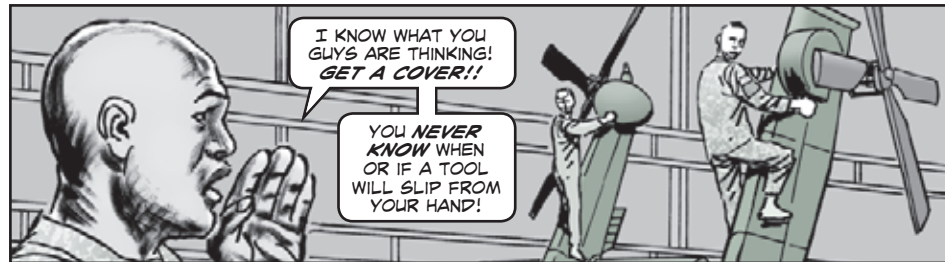

I KNOW WHAT YOU
GUYS ARE THINKING!
GET A COVER!!

YOU *NEVER*
KNOW WHEN
OR IF A *TOOL*
WILL SLIP FROM
YOUR HAND!

Mechanics, the last thing you need is to drop a tool on an uncovered Black Hawk or AH-64 stabilator.

So make covering the stabilator the first thing you do. Protect the stabilator using some type of foam, cushion or cover before doing tail rotor maintenance.

Even the best mechanics can have butterfingers and drop a hammer, wrench or screwdriver sometime.

Any of those tools can puncture, dent or damage an unprotected stabilator. If that happens, your aircraft will be grounded until support repairs minor nicks or dings—or replaces the entire stabilator if the damage is severe enough.

If you have an upholstery shop, or even a battalion ALSE shop, get them to make a right and left protective cover for the stabilator using these instructions. The cover is made from red vinyl and uses fire retardant and flame resistant foam as insulation, both of which you can purchase locally. Use the dimensions on the next page as your guide to making the cover.

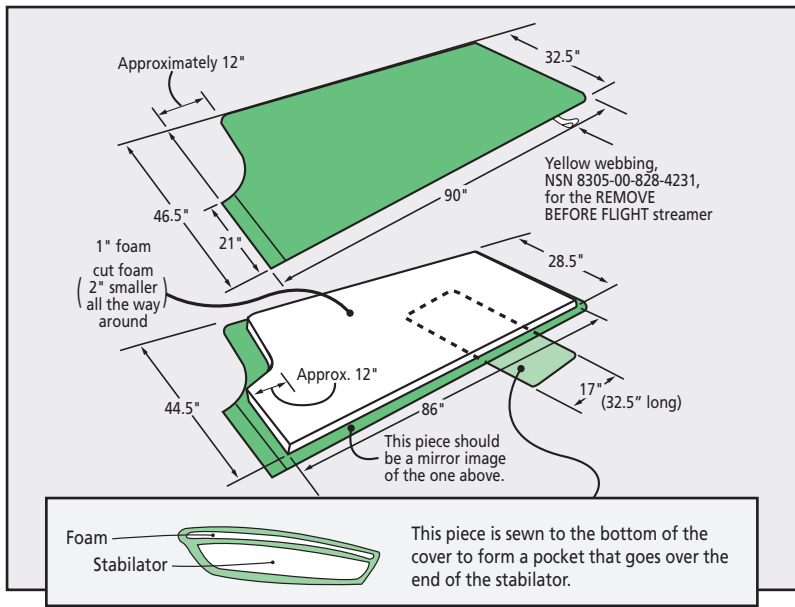

- Begin sewing the top and bottom together, leaving one of the long sides open for inserting the foam.
- After inserting the foam, finish sewing the two pieces together.
- Reinforce the opening edge of the pocket panel by folding it over 1 inch and sewing webbing on that edge. Sew in a web tab safety streamer.
- Then sew the panel to the cover. Leave a 7-in long opening 5 inches from the corner on the trailing edge to allow an opening for the static wick.
- Once you've made the first piece, make another one that's the mirror image of the first. (You need two pads—one for the left half of the stabilator and another for the right half.)
- The two pads will fasten together at the center of the stabilator with hook-and-pile fasteners as the diagram shows below.

Attach "Remove Before Flight" streamers to the sewn-in tabs.

If you can't make a cover, you can order a GSA approved alternative cover for your stabilator. For the UH-60A/L, you can get a digital cammo cover. You can also get an AH-64 stabilator cover. For the UH-60M, you can order a digital cammo stabilator cover. Check out these and other GSA approved covers and the current pricing at <http://www.gsaadvantage.gov> under contracts GS-07F-5768R and GS-07F-9386S.

Make a note that the California AVCRAD is **not** contracted to supply covers for the Army. So units need to either contract locally to have the cover made, make it themselves or order them from GSA Advantage.

Always remember, don't leave covers on while on the flight line because of blade rotor wash.

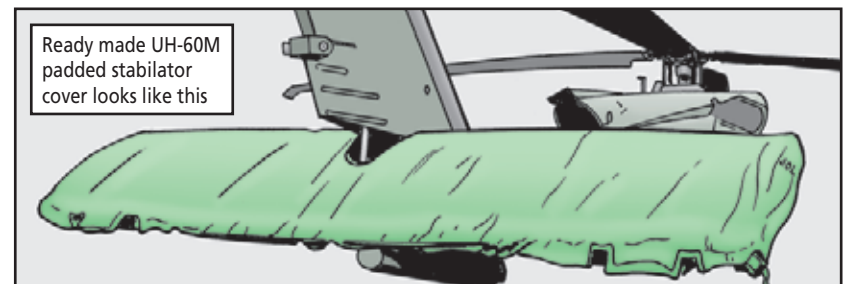
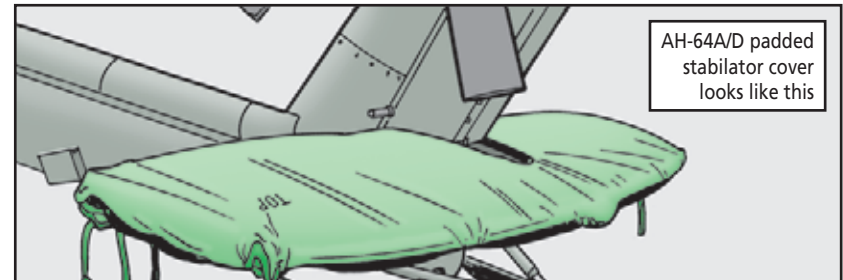
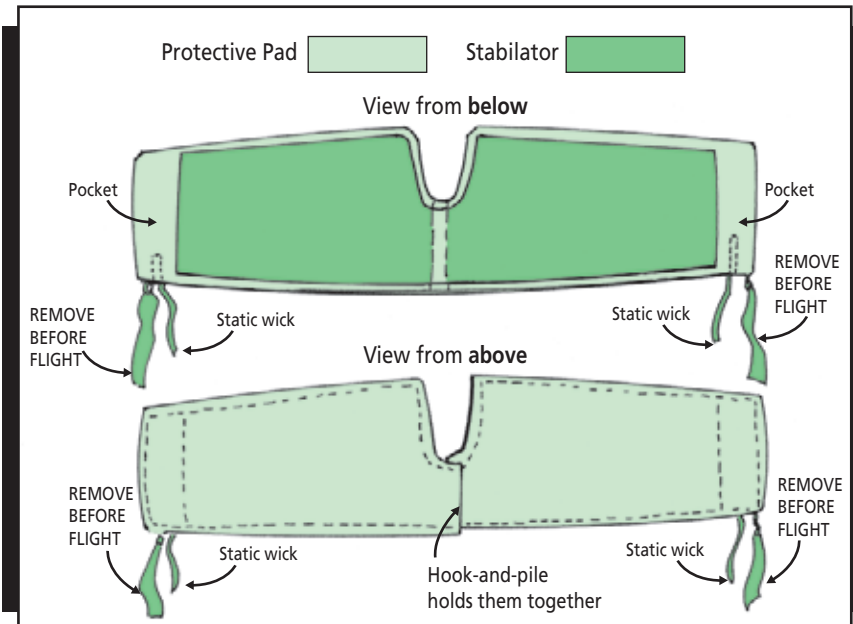

THE COLD HARD FACTS

WINTER'S BLAST IS A NIGHTMARE FOR YOU AND YOUR AIRCRAFT!

Plan, prepare and train for cold weather operations before the cold weather arrives! Review your unit's SOP for cold weather ops! Perform PMCS on your cold weather aircraft ground support equipment. Never forget to keep your cold weather clothing clean and serviceable. POL contaminated and dirty clothing will not protect you from the cold.

For general aircraft cold weather information, refer to Chapter 10 of TM 1-1500-204-23-1.

For Black Hawks (UH/HH-60A/L), you can find additional cold weather information in WP 1796 00 of TM 1-1520-237-23-12. For the M-model, check out your cold weather information in WP 1601 00 of TM 1-1520-280-23-12.

Here are some tips to help you win the cold, icy battle.

Tip One. When the mercury dips and a freeze kicks up, there is a two-step dance you should do. Plan your job out before you step out on the flight line and dress like a 5-minute maintenance job will take an hour. Bundle up and wear gloves. If you don't dress like you're going to Alaska, you'll rush the job, pull poor maintenance and risk exposure. Winter clothing may be bulky, but it allows you more time to do the job right while keeping warm. If you're shivering from the cold, maintenance won't get done the right way.

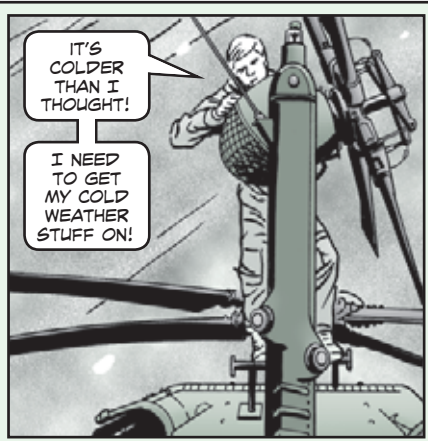

Tip Two. Cover your aircraft like your TMs tell you and you'll win the cold war against Mr. Freeze. If you can't cover the whole bird, at least cover up engine inlets, exhaust openings, and pitot tubes. For Black Hawk covers, check out WP 1729 00 of TM 1-1520-237-23-12. And for the UH/HH-60M, check out WP 1539 00 of TM 1-1520-280-23-12.



Tip Three. Warm the enclosed area and the aircraft with a portable duct type heater. Pre-heating a cold aircraft brings frozen metal and seals back to shape. It also warms cold lubricants and hydraulic fluids. Pre-heating aircraft reduces the strain on engines and transmissions and improves engine start-up too.

Keep a fire extinguisher handy when you're using a portable duct-type heater and keep the heater away from fuel and oil drains, vents and supply tanks and tentage. Avoid directly heating plastic and plexi-glass windshields and windows because heat can damage them.



Tip Four. Resist the urge to use shortcuts. Don't become a cold weather casualty. Be careful not to expose skin directly to a bitter cold aircraft, POL, or tools. They can cause frostbite. If Mr. Freeze gets to you, break your maintenance task into small portions or use the buddy system where one mechanic works while the other warms up in a shelter. Make sure you are extremely careful when climbing on to or walking on top of snow or frost covered aircraft because you could slip and fall off the aircraft!

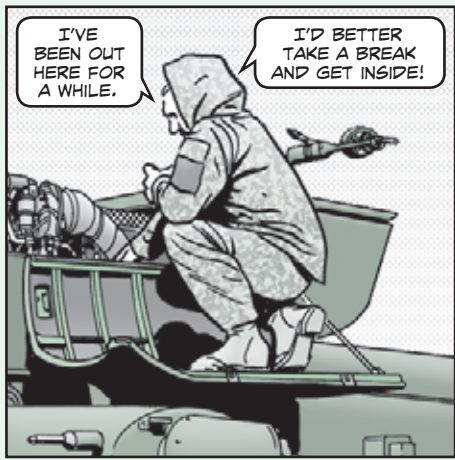

Tip Five. Always ground your aircraft. To beef up your knowledge on grounding, check out Page 2-11, in FM 10-67-1.

PS
END

All Aircraft...

NEED FUEL HANDLER COVERALLS?



PS 697



40

Fuel handlers, if you're looking for camouflage coveralls, don't hold your breath.

Camouflage coveralls are still in development. They won't be fielded for a while.

Fuel handler's coveralls, are available in tan. Here are the NSNs and sizes.

| NSN 8415-01-548- | Size |
|---------------------|----------|
| 5961 | X-small |
| 5967 | Small |
| 5966 | Medium |
| 5969 | Large |
| 5971 | X-large |
| 5973 | XX-large |

DEC 10

SINGGARS MT-6352/VRC...

FIRE PREVENTION!

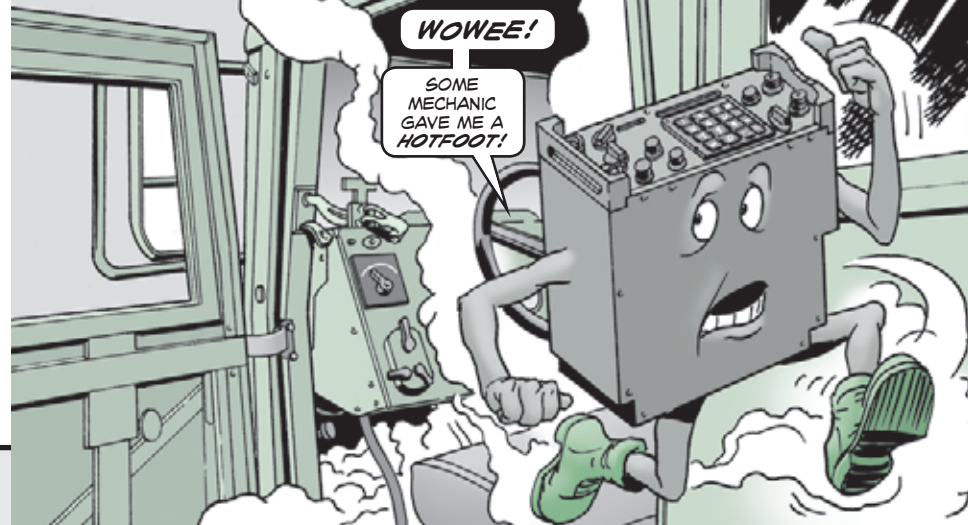

Dear Editor,

Please put the word out that a loose or incorrectly mounted E1 grounding wire inside the electrical connector assembly, NSN 5935-01-360-2630, of the MT-6352/VRC can burn out the EMI filter or the wiring.

So, when doing repairs of the electrical connector assembly, be sure that the E1 ground wire terminal lug is securely fastened to the EMI filter mounting screw. The screw is located near the end of the electrical connector. If the screw is missing, order a new one with NSN 5305-01-303-0311. And get a new washer with NSN 5310-01-540-5271.

David Yanosik
RDECOM, CERDEC
APG, MD

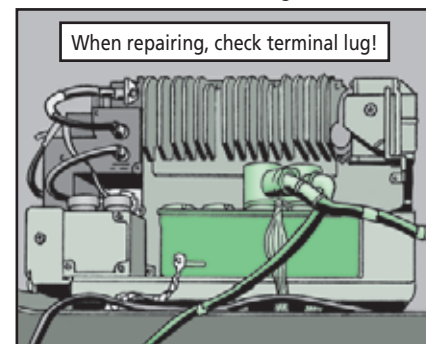

Editor's note: Thanks, David, for this important info. Maintainers, remember to do a continuity check to verify the ground when you replace or tighten the screw.

PS 697

41

DEC 10

Offset Kit Info

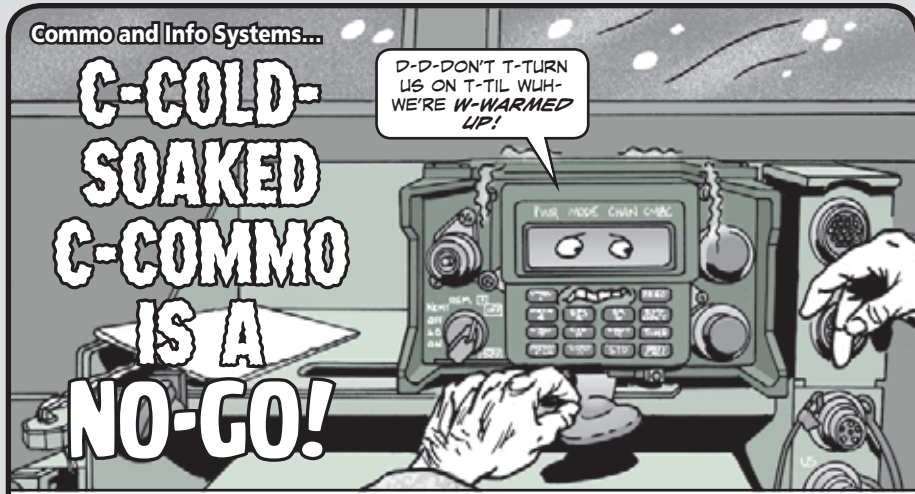
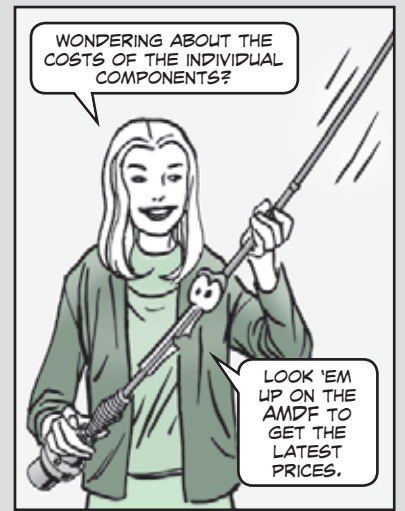
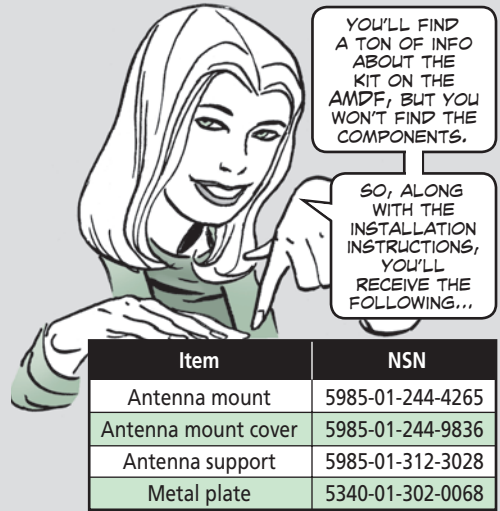
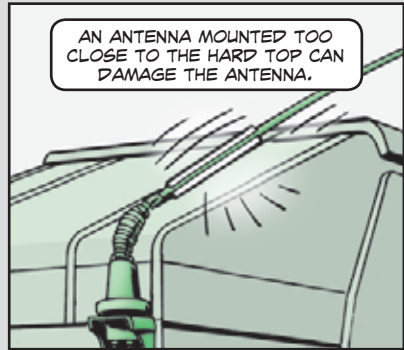
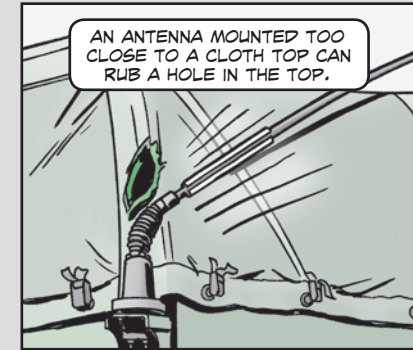
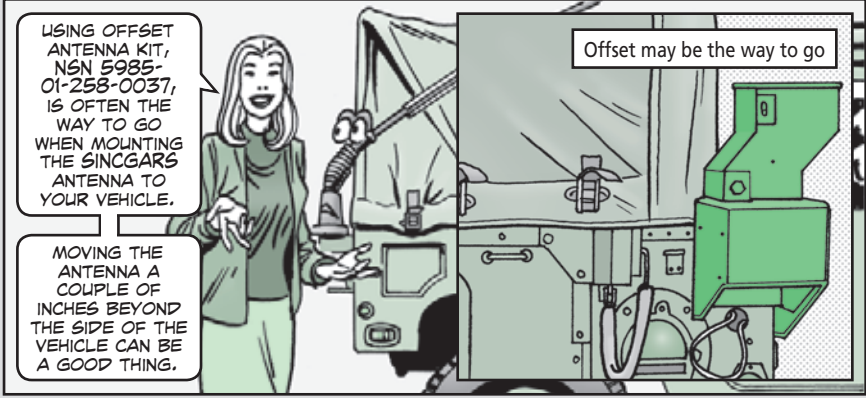
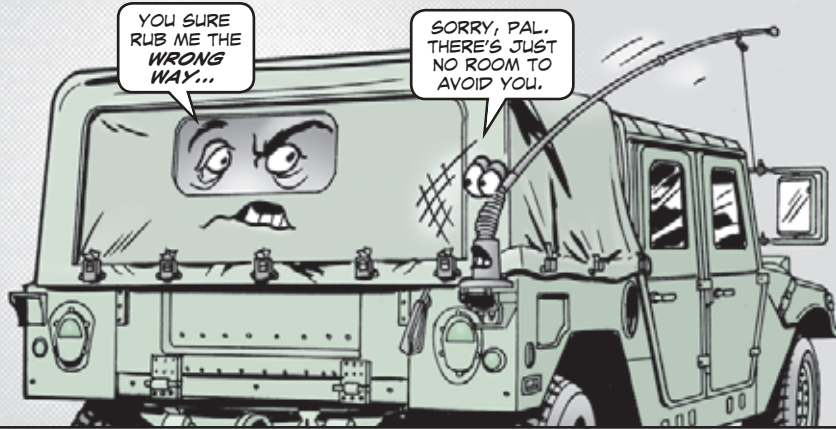

Commo and info systems left in cold-soaked vehicles must be allowed to warm up by surrounding warm air before they are turned on.

Computers and displays are not designed to operate at extremely cold temperatures. They might work, but the product will be diminished and it may be inaccurate.

So, warm the equipment environment before you switch on the equipment. If you know you can't do that, remove the equipment from a vehicle that might be cold-soaked overnight. Check the equipment TM for "operations under unusual conditions."

Dump Trucks...

HOIST CYLINDERS SHOULD LEAK!

HEY BUDDY! ONE OF MY HYDRAULIC HOIST CYLINDERS IS LEAKING!

DOES THAT MEAN I'M NMC?

NOT NECESSARILY!

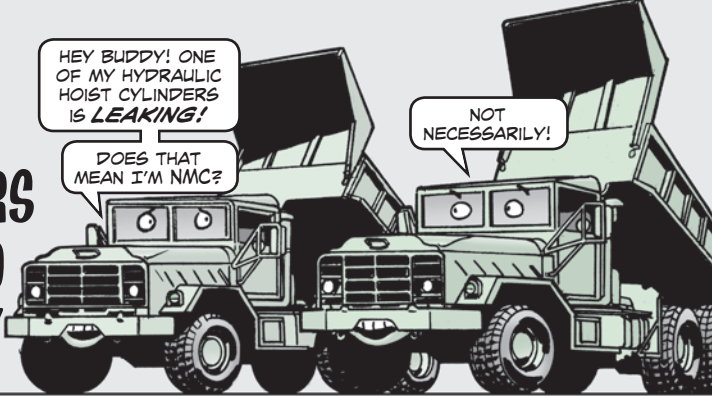

It's no secret that hydraulic hoist cylinders on M929- and M930-series dump trucks are known to leak. Some leak just a little, others leak a little more. Matter of fact, they're supposed to!

Your truck is not NMC unless the leak adds up to more than a quart a day, or the cylinders won't lift an empty dump body.

That's because single ram cylinders must leak enough to keep the cylinder rod coated with oil and the seal wet. The oil protects the rod from the elements and corrosion.

Telescoping cylinders, like the ones on these dump trucks, have seals at each section of the cylinders that leak for the same reason.

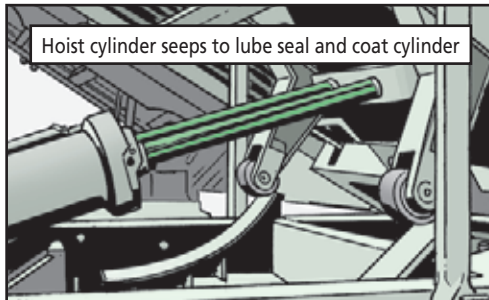

SINGGARS External Antenna Connector

The external antenna connector, NSN 5935-01-386-0360, for the RT-1523, -1523B and -1523C has been changed. It's now a snap-on connector instead of one that needs to be soldered. But it needs a new internal circuit card. Order both the new card and the connector with NSN 5895-01-384-4645.

Bookmark Battery Calculator Site

The Army's rechargeable battery program has a downloadable battery calculator called POWER. This calculator helps you determine the right battery for the equipment and the job. This site is updated often and recently has added more battery runtimes. So, add this site to your list of Internet favorites and check it often:

<https://www.monmouth.army.mil/cecom/lrc/lrchq/power/rechargeabat.html>

D5B, D7G and D8K Tractors...

Gage the Sprockets

WE'D BETTER CHECK THOSE TEETH!

BUT I JUST SAW THE DENTIST!



Construction operations cause the drive sprocket teeth on your dozer to wear down. Over time, enough wear can let the dozer's track jump right off the sprocket!

So before the day's run, check your dozer's teeth. Use a drive sprocket gage to measure sprocket wear. Order a gage to measure the D5B's sprockets with PN 5P8616 and CAGE 11083 from RIC S9C on a DD Form 1348-6. NSN 5210-01-225-1132 gets a gage for the D7G and D8K dozers.

HERE'S HOW TO GAGE THE SPROCKETS...

- Set the point of the gage marked for your tractor between the teeth of the drive sprocket.
- If the point doesn't touch, the sprocket's OK.
- If the point touches, the sprocket is shot and needs to be replaced by support.

If point touches between teeth—get drive sprocket replaced

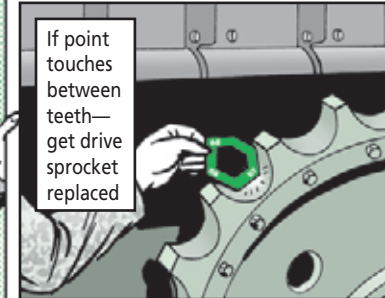

Transmission Filter Reminder

REPLACING THE TRANSMISSION'S PRIMARY FILTER DURING SCHEDULED SERVICES IS ONLY **HALF** THE STORY.

THE **OTHER** HALF IS MAKING SURE THE TRANSMISSION SYSTEM'S MAGNETIC STRAINER GETS CLEANED AT THE SAME TIME.

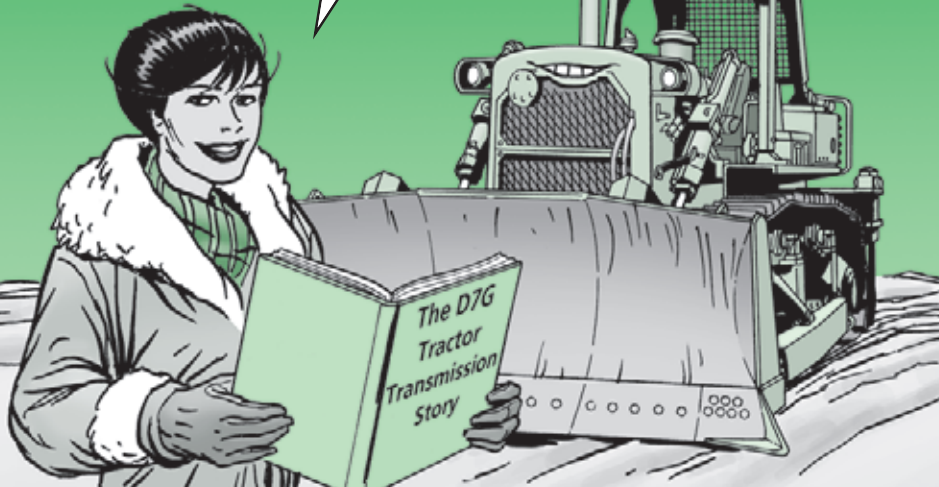

A CLOGGED SCREEN RESTRICTS OIL FLOW IN YOUR D7G'S TRANSMISSION.

THE RESULT IS WEAR AND TEAR IN THE ENGINE AND TRANSMISSION.



CLEANING THE SCREEN AND MAGNETS IS A 250-HOUR SERVICE IN LO 5-2410-237-12 AND TM 5-2410-237-20.

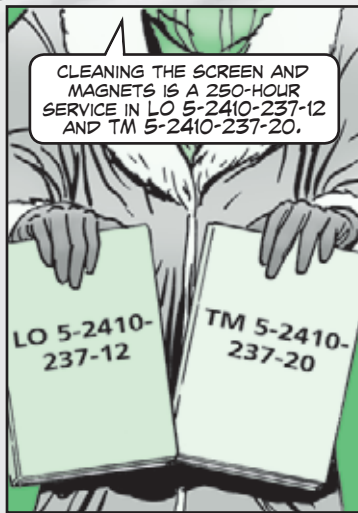

1. Remove the cover and spring, then remove the filter assembly.

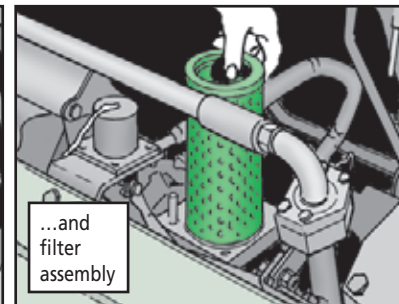
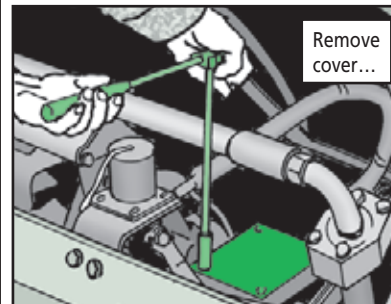

2. If you're in the motor pool, steam clean the screen and magnets and then dry them with pressurized air. In the field, wash the screen in MIL-PRF-680 Type III dry cleaning solvent. Clean the magnets with a stiff bristle brush. Do not use a wire brush! A wire brush will scratch or demagnetize them. And don't drop or tap the magnets—that can also demagnetize or break them.

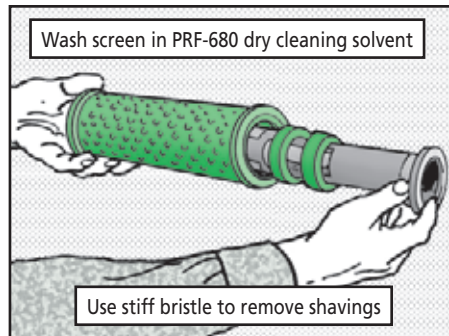

3. Check the cover seal for cracks, tears or mashed edges. If you find any, replace the seal with NSN 5330-00-863-5549.

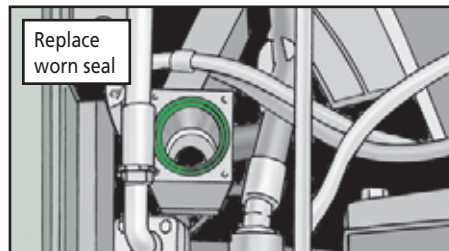

4. Install the magnets, screen, spring and cover, in that order. Torque the cover nuts to 31–34 lb-ft dry (no oil) or 23–25 lb-ft (threads lubed with oil).

5. With the engine running and the transmission in neutral, pull the dipstick to measure the oil level. Add oil to bring it to the FULL mark on the dipstick.

BANGED-UP CAB STEP

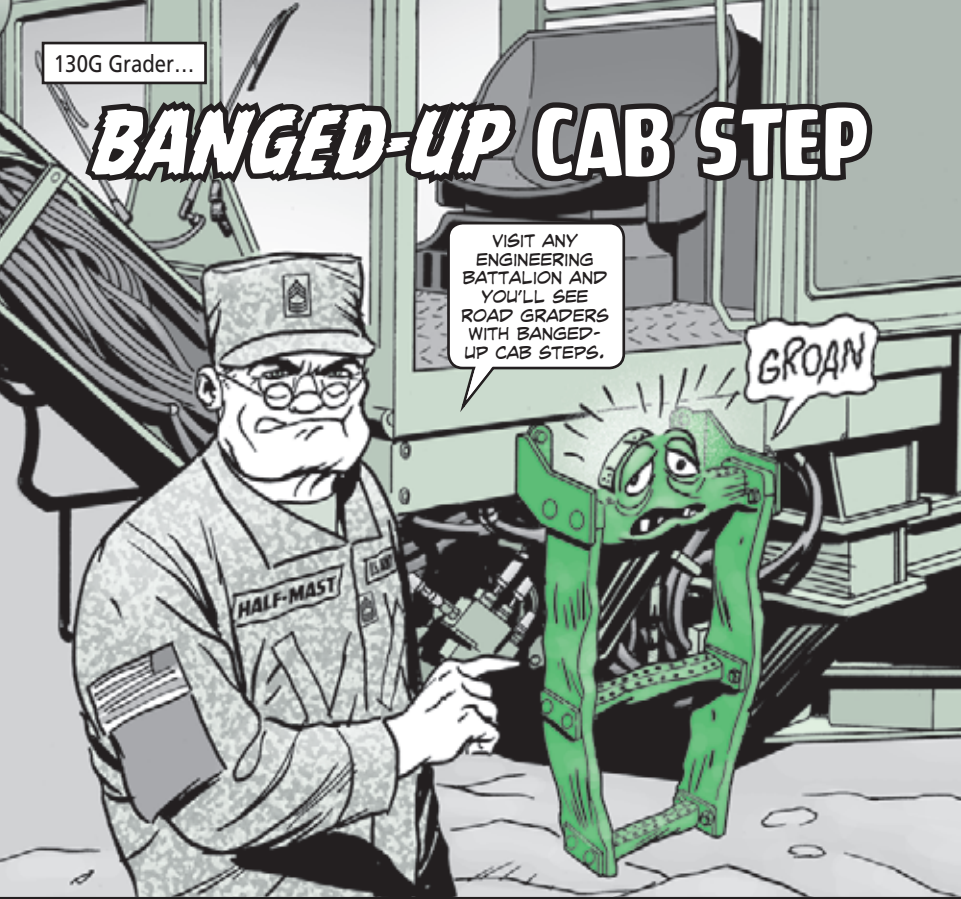

VISIT ANY ENGINEERING BATTALION AND YOU'LL SEE ROAD GRADERS WITH BANGED-UP CAB STEPS.

GROAN

Those steps take a hit when the grader's blade cuts a V-ditch, when the blade is raised, or when it's turned for travel. That's because the end of the blade is under the cab. Operators can't tell when it's about to snag the step and tear it off.

Unit mechanics can replace the old step with a rubber step assembly that bends forward and backward to keep from getting banged up or ripped off.

Eyeball Para 3-19 of TACOM's EIR Digest TB 43-0001-39-8 (Mar 96) for info on how to install the rubber step assembly.

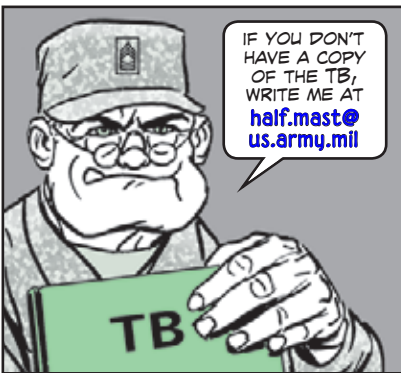

IF YOU DON'T HAVE A COPY OF THE TB, WRITE ME AT half.mast@us.army.mil

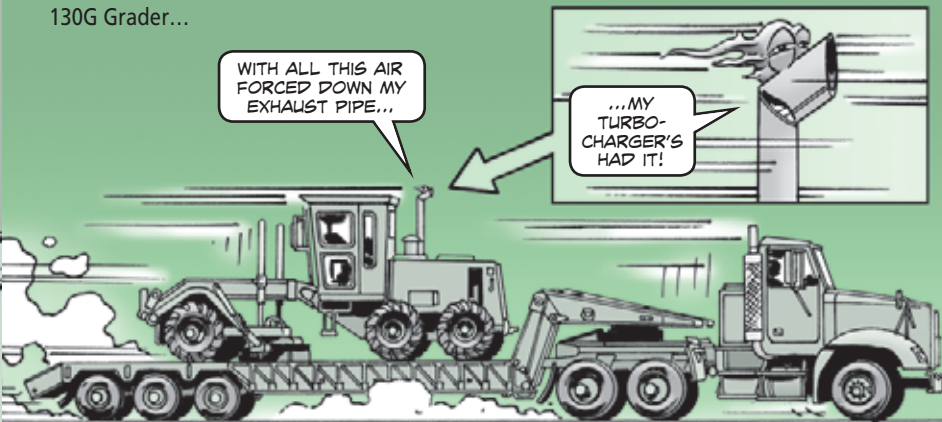

WITH ALL THIS AIR FORCED DOWN MY EXHAUST PIPE...

...MY TURBOCHARGER'S HAD IT!

NO TURBOCHARGER?

Your unit's grader went to the shop for annual checks and services. With those checks and services came back something else: A whopping bill for a new turbocharger!

"How come?" you ask.

Well, while transported on the back of a semitrailer, the exhaust pipe on this type of commercial construction equipment can face directly into the wind. That means air is being forced down the exhaust pipe into the turbocharger during transport.

All that forced air causes the turbocharger's impeller to spin without lubrication. Without oil being pumped to the impeller bearings, they burn out. The end result is no turbocharger.



- Use duct tape, NSN 5640-00-103-2254, and tape over the exhaust stack. That way no air gets forced down the stack and into the turbocharger. Just remember to remove the tape before startup.
- Have your mechanic loosen the exhaust pipe's pipe clamp. Turn the pipe so its opening faces the back of the trailer. Make sure to re-tighten the clamp.

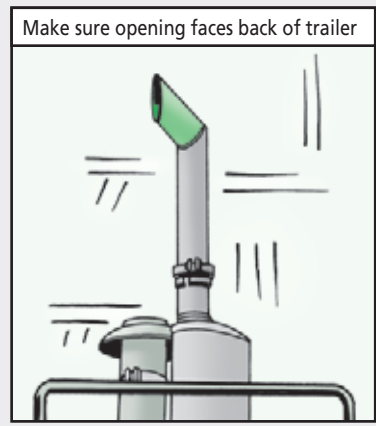

DON'T LET EXCESS ITEMS SIT

WE'RE NOT DOING ANY GOOD SITTING IN HERE *DOING NOTHING!*

YEAH, I WISH THEY WOULD TURN US IN SO A UNIT WHO NEEDS US COULD GIVE US WORK TO DO!

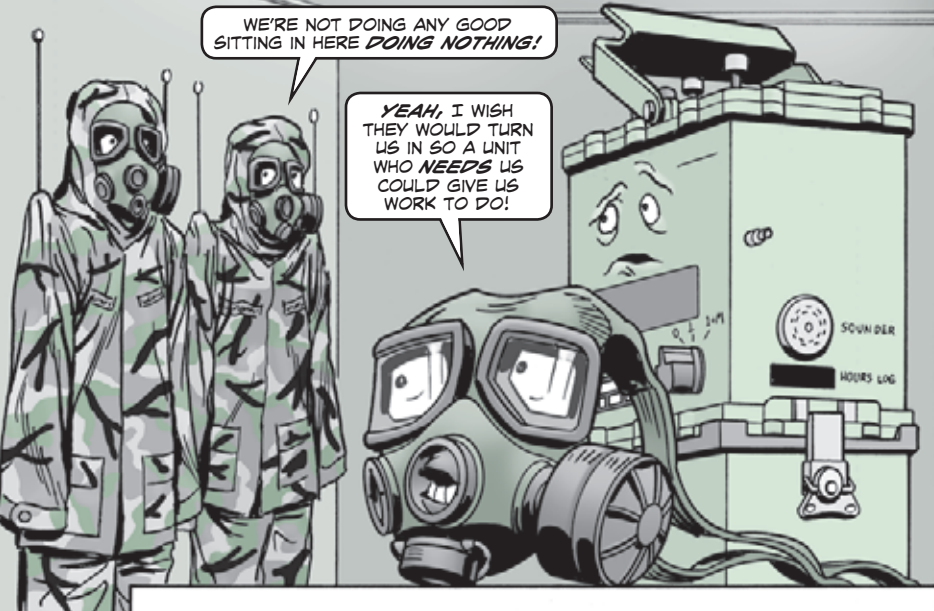

Dear Editor,

Through our work with the Ft Hood Command Maintenance Evaluation and Training Team (COMET), we run into many cases where excess or unserviceable CBRN items are left stored for months and even years.

That does no good for other units that might be able to use the excess equipment.

This is a particular problem with JSLIST (joint service lightweight integrated suit technology). When units prepare to deploy, they order new JSLIST. If the new suits don't come before they deploy, all the JSLIST goes into storage. Sometimes this can mean thousands of suits sitting in a warehouse serving no purpose. Meanwhile, the deployed units pick up the JSLIST they need overseas.

This waste can be avoided if units order JSLIST at least 45 days before they deploy. That provides enough time for the new JSLIST to arrive before units leave.

If units have excess CBRN equipment, they should contact the equipment's item manager for turn-in procedures. Your local TACOM logistics assistance representative can provide the item manager's contact info or you can look up the item manager by the item's NIIN:

https://aeeps2.ria.army.mil/services/supply/dsc_reqs/analcode/acsearch.html

For unserviceable or obsolete CBRN items, contact the Defense, Accountability, Reutilization, and Disposal (DARD) project. They handle all CBRN items that aren't classified as HAZMAT. HAZMAT items include M256/M256A1 detector kits, water testing kits, M11 decons, all types of batteries, simulator chemical agent detector tickets and mask canisters. These items must be disposed of through your installation environmental office.

To get DARD disposition instructions, email: smblogcomjeap@usmc.mil
Don't let CBRN equipment sit! Turn it in if you're not going to use it.

Vernon Gales
Shirley Evans
COMET
Ft Hood, TX

Editor's note: Thanks for the excellent info, Vernon and Shirley. Now CBRN specialists know what to do with equipment they aren't using.

WHAT OILS TO USE IN M26 DECON

TM 3-4230-238-23&P for the new M26 Decon system lists a German product for the water pump oil. That doesn't do you repairmen much good.

Until the updated TM hits the streets later this spring or summer, you should use SAE40 oil for the water pump.

PMCS calls for the pump oil to be changed annually. However, if the system hasn't been operated much and the oil appears to be clean (i.e., almond blond color—almost clear), your main-tenance SOP may dictate when to change it.

The engine itself uses 15W40 oil. Before changing the engine's oil, run the engine until you feel heat coming off the engine block. Add engine oil to the upper marking on the dipstick. It should take about 1 quart. Check out the procedure in Fig 1 of WP 0051 in the -23&P.

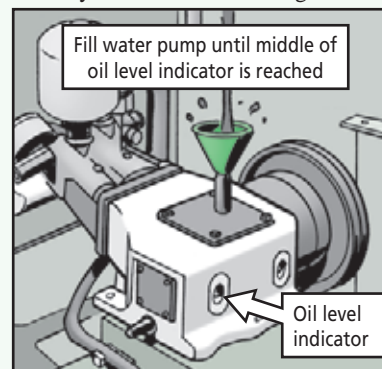

If you drain the water pump, use SAE40 oil to refill it until the oil is visible in the middle of the oil level sight glass. It should take about 2.1 quarts.

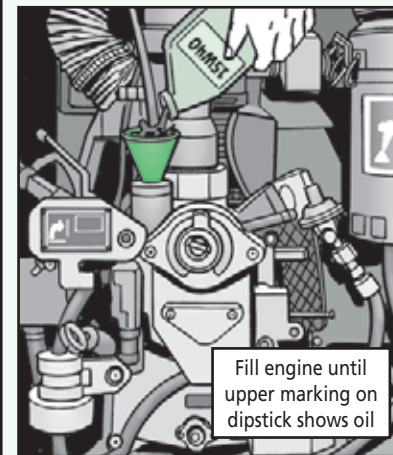

Clearing Up SMR Codes



DON'T TELL ME -- SOMEONE SENT AN EMAIL WITH A QUESTION CONCERNING SMR CODES.

DING



YEP. SOME DAYS IT SEEMS THE ONLY EMAIL I GET ARE THOSE QUESTIONS... AND OFFERS FROM NIGERIAN PRINCES AND HONG KONG BANKERS!

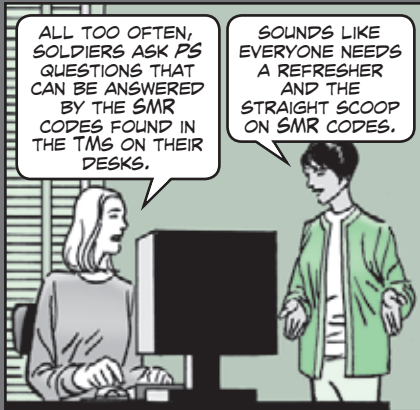

ALL TOO OFTEN, SOLDIERS ASK PS QUESTIONS THAT CAN BE ANSWERED BY THE SMR CODES FOUND IN THE TMS ON THEIR DESKS.

SOUNDS LIKE EVERYONE NEEDS A REFRESHER AND THE STRAIGHT SCOOP ON SMR CODES.

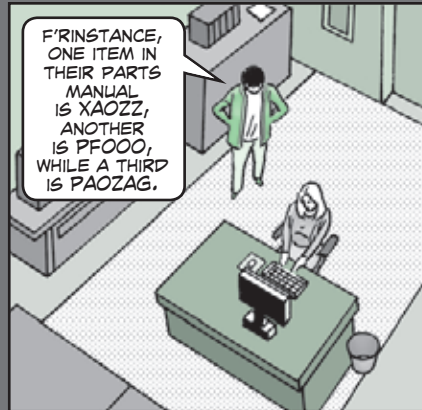

F'RINSTANCE, ONE ITEM IN THEIR PARTS MANUAL IS XAOZZ, ANOTHER IS PFOOO, WHILE A THIRD IS PAOZAG.



THESE FIVE OR SIX LETTERS ARE *NOT* RANDOM!

IN EACH CASE, THEY TELL YOU ABOUT AN ITEM'S SOURCE, MAINTENANCE AND RECOVERABILITY (SMR).



WHAT ARE SMR CODES?

SMR codes are found at the beginning of every Repair Parts and Special Tools List section in TMs ending with a "P" or "&P." The code format has four parts: a two-position source code, a two-position maintenance code, a recoverability code and an optional service-specific code.



WHY DO WE NEED TO USE CODES?

Imagine the logistical nightmare if every unit made up and used their own codes! SMR codes keep the Army on-the-go by giving a ton of info about items that can be correctly and universally "decoded" at every level, from the joint services down to the individual Soldier.

The Big Breakdown

Source

The first and second positions of the code both refer to an item's source.

The first position gives a general category and is always one of five letters:

- P – Procured.** Items with a P are centrally procured.
- K – Kit.** Usually items in kits don't have NSNs. (**Note:** In cases where an item is part of a kit and is also an item outside the kit, the P series source code is used).
- M – Manufactured.** The item is manufactured or fabricated at one of the maintenance levels.
- A – Assembled.** The item is assembled at one of the maintenance levels.
- X – Not stocked.** (See "Key to X Codes" for descriptions).

Key to X Codes

X series source codes are items for which little or no demand is expected.

- XA** – Item is not procured or stocked because this item requires you to replace the next higher assembly.
- XB** – A support item not expected to fail and not stocked. In some cases, it may be available through salvage. If not available or authorized through salvage, order the item through normal supply channels using its CAGE code and reference number.
- XC** – An installation drawing, diagram, instruction sheet or field service drawing identified by a manufacturer's part number.
- XD** – A support item that is not expected to fail but **cannot** be replaced by salvage/cannibalization. Local purchase or requisition this item through normal supply channels using its CAGE code and reference number.



Second Position

The second position adds specific info to the general source code of the first position. For example, PA is a procured and stocked item, and PH is a stocked and procured item but contains HAZMAT and so it has special reporting requirements. PZ means an item was once procured but is now terminal or obsolete with no replacement, so you need to stop using it.

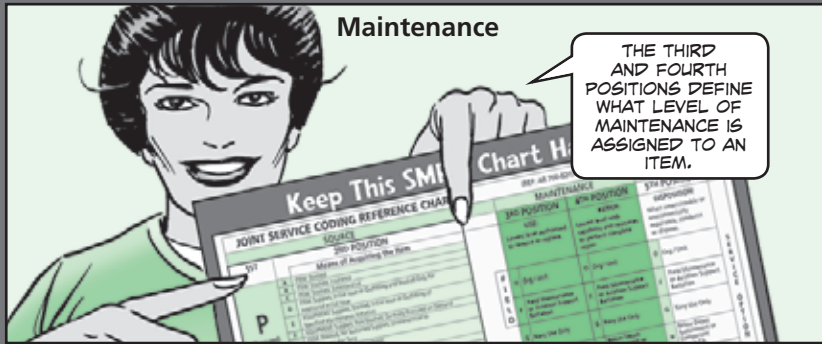

Third Position

The lowest authorized level authorized to remove, replace or use the item is defined by the code here:

- O – Organizational Level
- F – Field Maintenance or Aviation Support Battalion
- H – Below Depot Sustainment or Component Repair Company
- K – Contractor Facility
- L – Special Repair Activity
- D – Depot, Mobile Depot and Specialized Repair Activity

IN ARMY PROGRAMS, A CODE "C" MAY BE USED IN THE THIRD POSITION TO DENOTE CREW OR OPERATOR MAINTENANCE PERFORMED WITHIN ORGANIZATIONAL MAINTENANCE.

IN JOINT PROGRAMS, THE ARMY WILL USE CODE "O" TO INDICATE A SERVICE COMPANY OR AVIATION MAINTENANCE COMPANY.



Fourth Position

The fourth position uses the same codes as position three, but tells you the lowest maintenance level that is capable and has the resources to perform a complete repair.

A “complete repair” means the item will return to service when repaired. A “complete repair action” means that all maintenance (remove, replace, repair, assemble and test) for the item must be performed at that level.

A code “Z”, meaning **nonreparable**, may also be used in positions 4 and 5. Z-coded parts need to be replaced when they go bad.

Fifth Position

Recoverability is defined in the fifth position. The code tells you what maintenance level can determine when an item is unserviceable or uneconomically repairable, and who can condemn or dispose of the item.

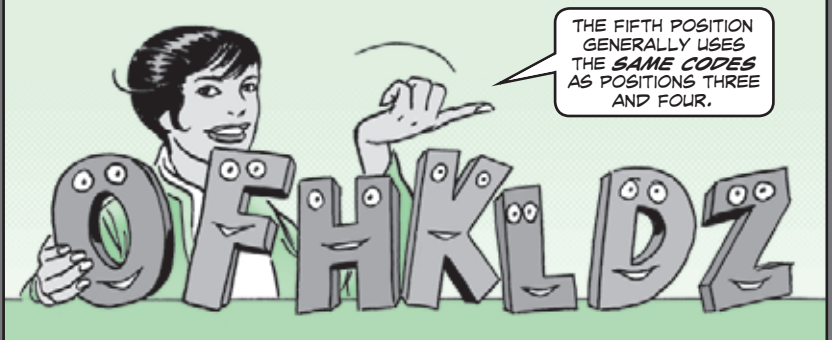

Sixth Position

A sixth position is optional and service-specific. For instance, an “A” code in the sixth position means no demilitarization is required upon disposal. A “G” code refers to a military list item that must be demilitarized before it goes to the DLA Disposition Services.

For more information and a complete list of codes and definitions, see AR 700-82, *Joint Regulation Governing the Use and Application of Uniform Source Maintenance and Recoverability Codes* (10 Oct 07).

THE CHART ON THE FOLLOWING PAGES HAS BEEN SIMPLIFIED TO SHOW THE MOST COMMON SMR CODES SEEN IN THE ARMY.

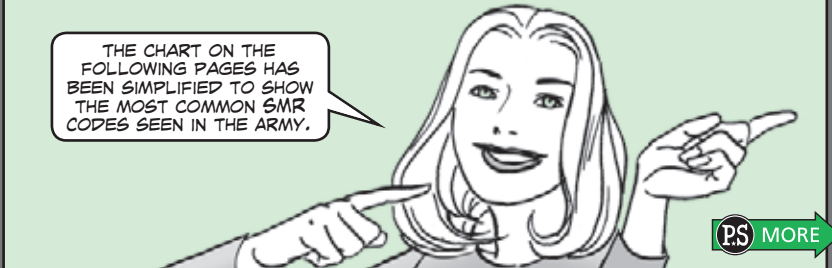

Keep This SMR Chart Handy!

JOINT SERVICE CODING REFERENCE CHART

(REF: AR 700-82/OPNAVIST4410.2/MCO 4400.120)

| SOURCE | | MAINTENANCE | | RECOVERABILITY | |
|--|--|---|--|--|--|
| 1ST | 2ND POSITION | 3RD POSITION | 4TH POSITION | 5TH POSITION | 6 |
| | Means of Acquiring the Item | USE: | REPAIR: | DISPOSITION: | |
| P (Procured) | A ITEM: Stocked | Lowest level authorized to remove or replace. | Lowest level with capability and resources to perform complete repair. | When unserviceable or uneconomically repairable, condemn or dispose. | |
| | B ITEM: Stocked, Insurance | | | | |
| | C ITEM: Stocked, Deteriorative | | | | |
| | D ITEM: Support, Initial Issue or Outfitting and Stocked Only for Additional Initial Issue | | | | |
| | E EQUIPMENT: Support, Stocked, Initial Issue or Outfitting of Specified Maintenance Activities | | | | |
| | F EQUIPMENT: Support, Non-Stocked, Centrally Procured on Demand | | | | |
| | G ITEM: Stocked, for Sustained Support, Uneconomical to Produce at Later Time | | | | |
| | H ITEM: Stocked, Contains HAZMAT. HMIS/MSDS Reporting Required | | | | |
| | R Terminal or Obsolete, Replaced | | | | |
| Z Terminal or Obsolete, Not Replaced | | | | | |
| K (Kit) | D ITEM: Depot O/H & Maintenance Kits | Navy Use Only | Navy Use Only | Navy Use Only | |
| | F ITEM: Maintenance Kit, Place at O,F,H,L | | | | |
| | B ITEM: in Both Depot Repair & Maintenance Kits | | | | |
| M (Manufactured) | O MFG OR FAB at Unit Level | Below Depot Sustainment or Component Repair Co. | Below Depot Sustainment or Component Repair Co. | Below Depot Sustainment or Component Repair Co. | |
| | F MFG OR FAB at Field Maintenance or Aviation Support Battalion Level | | | | |
| | H MFG OR FAB at Below Depot Sustainment or Component Repair Co Level | | | | |
| | L MFG OR FAB at Specialized Repair Activity (SRA) | | | | |
| | G MFG OR FAB Both Afloat and Ashore (Navy Only) | | | | |
| D MFG OR FAB at Depot Maintenance Level | | | | | |
| A (Assembled) | O ITEM: Assembled at Unit | Specialized Repair Activity | Specialized Repair Activity | Not Authorized Below Depot Level | |
| | F ITEM: Assembled at Field Maintenance or Aviation Support Battalion Level | | | | |
| | H ITEM: Assembled at Below Depot Sustainment or Component Repair Co Level | | | | |
| | L ITEM: Assembled at SRA | | | | |
| | G ITEM: Assembled Afloat and Ashore (Navy Only) | | | | |
| D ITEM: Assembled at Depot Maintenance Level | | | | | |
| X (Not Stocked) | A ITEM: Requisition Next Higher Assembly | Depot, Mobile Depot and Specialized Repair Activity | Depot, Mobile Depot | Condemn or Dispose at Depot | |
| | B ITEM: Not Procured or Stocked. Available thru salvage. Req by CAGE/Part Number. | | | | |
| | C Installation Drawing, Diagram, Instruction Sheet. Identify by Cage/Part Number. | | | | |
| | D Not Stocked. Obtain via Local Purchase. | | | | |
| | | F | O | O | S E R V I C E O P T I O N C O D E S |
| | | F | F | F | |
| | | G | G | G | |
| | | H | H | H | |
| | | K | K | K | |
| | | L | L | L | |
| | | D | D | D | |
| | | Z | Z | Z | |
| | | | B | A | |



COLD WEATHER WEB PAGE

In the battle against the cold, knowledge is your best defense. So, arm yourself with all the facts about cold weather injuries. Visit the U.S. Army Public Health Command (Provisional) website: <http://phc.amedd.army.mil/home/>

From the home page, click on [A-Z Index](#). On the next page, click on [Cold Weather Casualties and Injuries](#). You'll find a variety of documents covering causes, symptoms, first aid and prevention.

Bullet OK to Adjust M16/M4 Sight

On Page 19 in PS 693 (Aug 10), we told you not to adjust the M16 rifle/M4 carbine front sight with a bullet or multi-purpose tool. That was partially wrong. It is OK to adjust the sight with a bullet or with the special tool shown in WP 0030-3 in TM 9-1005-319-23&P. But if you adjust the sight with a multi-purpose tool or a nail, you'll eventually ruin the sight.

M1A1 AIM SA TANK SIDECAR SMR CODE

If any sidecar assembly fails on your M1A1 AIM SA (situational awareness) tank, don't toss it in the trash. The SMR code for both the V1 sidecar, NSN 6625-01-497-1915, and the V3 sidecar, NSN 6110-01-577-1839, has recently changed to PAFLL. That means they both can be repaired by a special repair activity and should be turned in for serviceable/unserviceable credit.

DLA Renames Field Activities

The Defense Logistics Agency (DLA) has renamed its field activities to show clear affiliation with DLA.

Here are some examples:

| Old name | New name |
|---|-----------------------------------|
| Defense Supply Center Columbus | DLA Land and Maritime |
| Defense Supply Center Philadelphia | DLA Troop Support |
| Defense Supply Center Richmond | DLA Aviation |
| Defense Energy Support Center | DLA Energy |
| Defense Reutilization and Marketing Service | DLA Disposition Services |
| Defense Distribution Center | DLA Distribution |
| Defense Logistics Information Service | DLA Logistics Information Service |
| Document Automation and Product Service | DLA Document Services |
| Defense Automatic Addressing System Center | DLA Transaction Services |
| Defense National Stockpile Center | DLA Strategic Materials |

For more information, and to see the complete list of name changes, visit: <http://www.dla.mil/wearedla.aspx> Or email: WeAreDLA@dlamil

SECURE AND STOW WEAPONS CORRECTLY ON COMMERCIAL AIRCRAFT

When deploying, follow Defense Transportation Regulations by removing bolts from weapons and packing them in your checked baggage. A second option is to leave weapon bolts in place, but insert flag safety sticks, NSN 1005-00-418-8557, to lock the bolts.

M2 Feed Tray Cover Pin

The cotter pin used to secure the M2 machine gun's feed lever to the feed tray cover was accidentally left out of TM 9-1005-213-23&P (Mar 02). Until the cotter pin is added in the next TM change, the belt feed retaining lock pin, NSN 5315-00-013-7137 (PN MS24665-814), or the cotter pin, NSN 5315-00-842-3044 (PN MS244665-283), can be used instead.

M1152A1 HMMWV Fire Extinguisher NSN

The NSN for your M1152A1 HMMWV's fire extinguisher, shown as Item 11 in Fig 266N of TM 9-2320-387-24P (Mar 02, w/ Ch 4, Mar 08), is wrong! Order the right one using NSN 4210-01-562-0852—not NSN 4210-01-525-6692. The part number listed in the TM is correct.

M984A4 HEMTT ELECTRICAL CONTROL BOX

TM 9-2320-326-14&P (EM 0288) gives the wrong NSN for your M984A4 HEMTT's electrical control box. Item 4 of Fig 57 should show NSN 5975-01-558-4419 with part number 3642776. This correction should appear in the next HEMTT -A4 IETM update.

M915A2/M916A1 Tachometer Kit NSN Change

Use NSN 6680-01-540-3074 to get the tachometer kit for your M915A2 and M916A1 tractor trucks. It replaces NSN 6680-01-502-6523, a terminal item, shown as Item 1 in Fig 335 of TM 9-2320-363-24P.

"MUST SEE" GRS TRAINING VIDEO

Need help with the proper wear of your vehicle's gunner's restraint system? Then take a few minutes to eyeball TACOM's gunner's restraint system informational video online: <https://atn.army.mil>

This video is **mandatory** for operators and supervisors. Just log in with your CAC, click on [Videos](#) on the top menu, click on [Training Skills Videos](#) on the left, then select [The Gunner's Restraint System](#) from the drop-down menu.

DISTRIBUTION: To be distributed in accordance with the initial distribution number (IDN) 340312, requirements for TB 43-PS-Series.

Would You Stake Your Life ^{right now} on the Condition of Your Equipment?

*Whether You're Carrying
a Duffel Bag or a Sack...*



*...Mission Completion Depends on
Preventive Maintenance*